

WSL/WSR WAL/WAR

GRAVITY SKATEWHEEL SPUR CONVEYOR

Gravity skatewheel spurs are used to transfer product from one conveying line onto another. They are suitable for merging or diverging applications.

- 4 widths
- Powder coated steel or aluminum frames
- 30, 45 and 90 degree spurs



STEEL FRAMES														
OAW	30° SPUR				45° SPUR				90° SPUR					
	MODEL NO.	"A"	WPS	WT. (LBS.)	MODEL NO.	"A"	WPS	WT. (LBS.)	MODEL NO.	"A"	"B"	"R"	WPS	WT. (LBS.)
12"	WS(L/R)-12-30	24 3/8"	51	39	WS(L/R)-12-45	21"	54	39	WS(L/R)-12-90	30"	39 1/8"	36"	46	67
15"	WS(L/R)-15-30	30 3/8"	67	43	WS(L/R)-15-45	30"	70	43	WS(L/R)-15-90	39"	35 5/8"	33"	56	72
18"	WS(L/R)-18-30	36 3/8"	71	47	WS(L/R)-18-45	30"	77	47	WS(L/R)-18-90	39"	32 11/16"	30"	60	77
24"	WS(L/R)-24-30	48 3/8"	83	57	WS(L/R)-24-45	39"	97	57	WS(L/R)-24-90	51"	39 1/2"	36"	94	107

ALUMINUM FRAMES														
OAW	30° SPUR				45° SPUR				90° SPUR					
	MODEL NO.	"A"	WPS	WT. (LBS.)	MODEL NO.	"A"	WPS	WT. (LBS.)	MODEL NO.	"A"	"B"	"R"	WPS	WT. (LBS.)
12"	WA(L/R)-12-30	24 3/8"	51	26	WA(L/R)-12-45	21"	54	26	WA(L/R)-12-90	30"	39 1/8"	36"	46	45
15"	WA(L/R)-15-30	30 3/8"	67	29	WA(L/R)-15-45	30"	70	29	WA(L/R)-15-90	39"	35 5/8"	33"	56	47
18"	WA(L/R)-18-30	36 3/8"	71	32	WA(L/R)-18-45	30"	77	32	WA(L/R)-18-90	39"	32 11/16"	30"	60	51
24"	WA(L/R)-24-30	48 3/8"	83	38	WA(L/R)-24-45	39"	97	38	WA(L/R)-24-90	51"	39 1/2"	36"	94	71

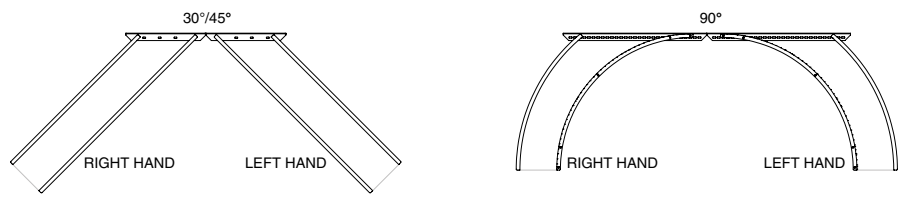
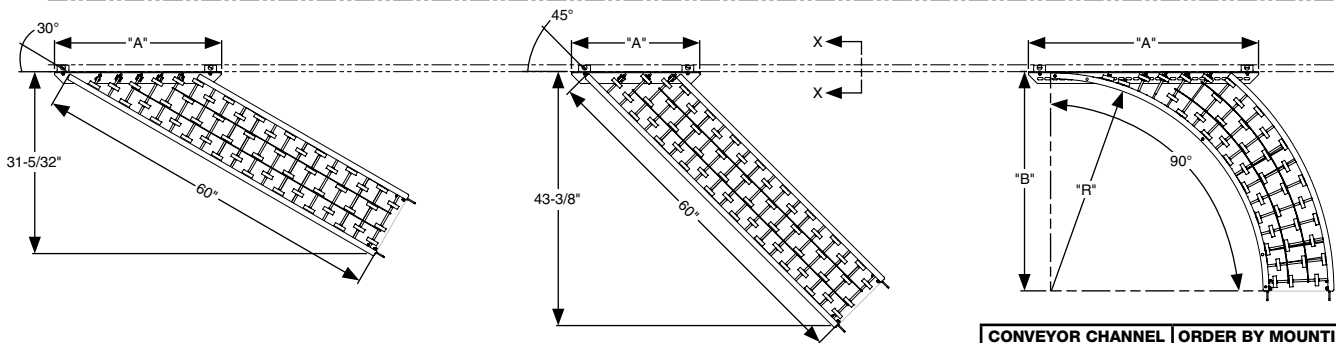

CONVEYOR CHANNEL SIZE "H"	ORDER BY MOUNTING BRACKET NO.
2 1/2 x 12 ga. Steel	ATL-10313
3 1/2 x 10 ga. Steel	ATL-11745
6 1/2 x 12 ga. Steel	ATL-13082

STANDARD SPECIFICATIONS

- FRAME** – 2 1/2 in. deep x 1 in. flange x 12 ga. powder coated steel or 1/8 in. aluminum channel with bolt-in cross members
- WIDTHS** – 12 in., 15 in., 18 in., and 24 in. overall width
- SPUR ANGLES** – 30, 45 and 90 degree. Specify right hand or left hand.
- COUPLINGS** – Hooks and bolts one end. Shelf angle on the opposite end. Specify shelf angle mounting bracket.
- WHEELS** – 1 15/16 in. dia., ball bearings run in hardened raceway with life time lubrication. Corrosion-resistant aluminum or zinc plated steel.
- AXLES** – 1/4 in. dia. threaded one end with locknut on 3 in. centers

OPTIONAL EQUIPMENT

- SUPPORTS** – Tripod stands and stationary floor supports are available in a wide range of adjustments
- WIDTHS** – Other in-between widths from 12 in. to 30 in. overall width
- WHEELS/COVERS** – Black or white plastic wheels are available in place of steel or aluminum wheels. Black neoprene covers are also available.
- BUTT COUPLINGS** – In place of hooks and bolts, these brackets allow a more permanent connection with adjacent conveyor
- GUIDE RAILS** – Adjustable channel guide rails, fixed angle and channel guide rails