

FMS19T

FLAT MOTOR CONVEYOR (1.9 in. dia. x 16 ga. rollers)

The FMS19T live roller conveyor is ideal for transporting boxes or totes. Tread rollers are powered by 24VDC motors making it simple to install and maintain. It is also quiet to operate.



- 12 widths
- 24 VDC motors
- Quiet operation

	CONVEYOR WEIGHT (LBS.)											
	BETWEEN FRAME WIDTH											
	13"	15"	17"	19"	21"	23"	25"	27"	31"	33"	37"	39"
	OVERALL FRAME WIDTH											
	16"	18"	20"	22"	24"	26"	28"	30"	34"	36"	40"	42"
10' LENGTH	310	325	340	355	370	385	400	410	435	450	480	495
PER FOOT	19	20	21	23	24	26	27	28	31	32	35	36

Note: Bed sections are available from 2 ft. to 10 ft. in 6 in. increments

STANDARD SPECIFICATIONS

BED – 6 1/2 in. deep x 1 1/2 in. flange x 12 ga. powder painted formed steel channel frame with 1.9 in. dia. x 16 ga. galvanized tread rollers spaced on 3 in. centers. Sections bolted together with butt couplings.

CROSS BRACING – Rods with turnbuckles are fastened to underside of bed to provide squaring adjustment and ensure correct product tracking. One set of turnbuckles are supplied for every 50 ft. of conveyor.

MOTOR – 24 VDC flat motor mounted on inside of conveyor frame. Maximum of 16 rollers can be slaved by each motor.

MOTOR DRIVER CARD – One required for each motor

DRIVE/SLAVE BELTS – 3/16 in. dia. urethane belts from motor drive spool to rollers and roller to roller

POWER SUPPLY – 40 AMP DC power supply to power motors. 115/230 VAC single phase input, 24 VDC output. Mounted near center of conveyor.

BEARINGS – Tread rollers have grease packed ball bearings

CONVEYING SPEED – 50-174 FPM. Selectable on motor drive card.

CAPACITY – Maximum load of 37 lbs. per linear not to exceed 75 lbs. per motor. If products will be loaded "back to back", use the following chart for capacity per linear foot.

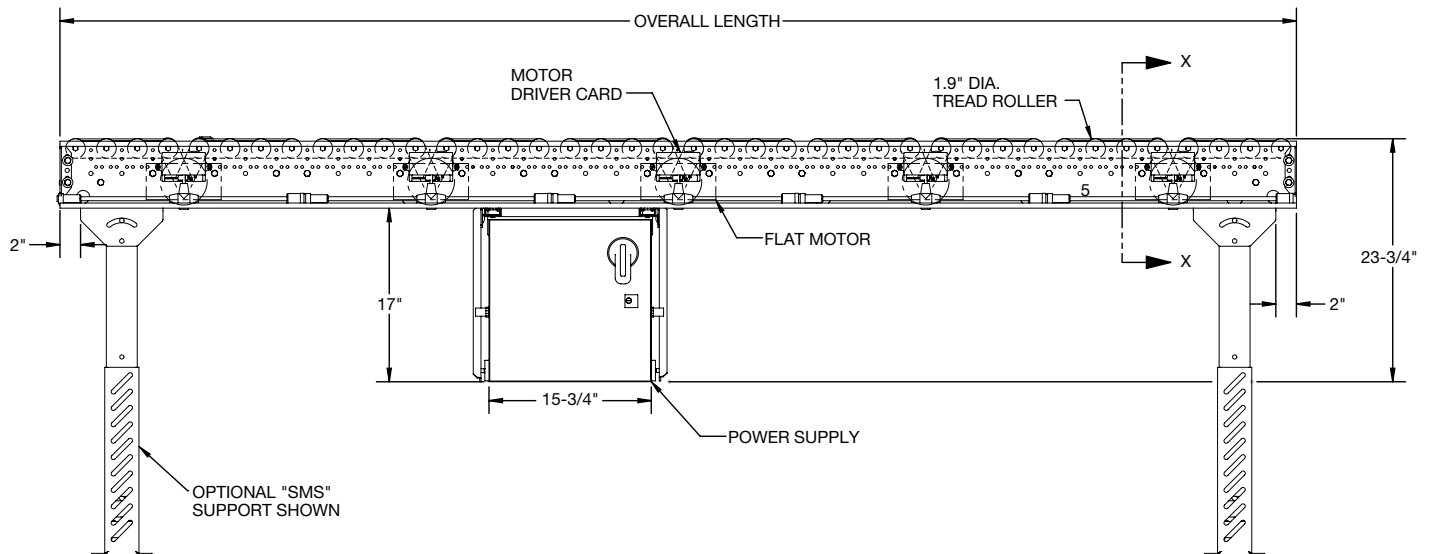

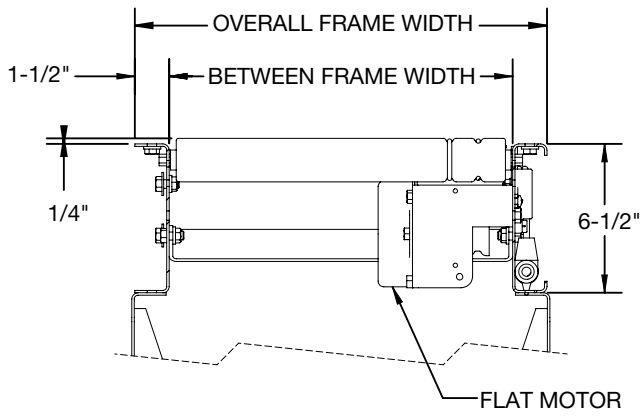

SECTION X-X

CAPACITY IF PRODUCTS ARE LOADED BACK TO BACK		
BED SECTION LENGTH	NO. OF MOTORS IN SECTION	CAPACITY (LBS. PER FOOT)
2'-0"	1	37
2'-6"		30
3'-0"		25
3'-6"		21
4'-0"		19
4'-6"	2	33
5'-0"		30
5'-6"		27
6'-0"		25
6'-6"		23
7'-0"		21
7'-6"	3	20
8'-0"		19
8'-6"		26
9'-0"		25
9'-6"	3	23
10'-0"		22

OPTIONAL EQUIPMENT

FLOOR SUPPORTS – SMS type floor supports are available with a wide range of adjustment. Specify top of roller elevation. One support required at every bed joint and ends of conveyor. Holes in feet for lagging to floor. Knee braces included on SMS-7 support and above.

POWER SUPPLY – Other power supplies are available based on system need.

- 5 AMP power supply (3 motors maximum)
- 10 AMP power supply (10 motors maximum)
- 20 AMP power supply (20 motors maximum)

ROLLER CENTERS – Tread rollers spaced every 2 in.

GUIDE RAILS – Adjustable channel guide rail and fixed angle guide rails. Note: If product comes into contact with guide rails, product flow may be affected.

OTHER ACCESSORIES – Poly-tier supports, ceiling hangers. See accessory section.

FMC19T

FLAT MOTOR CURVE (Tapered rollers)

The FMC19T live roller curves are compatible with straight sections and spurs providing flexibility to your conveyor line. Dependent upon the degree, each curve includes one or two motors.

- 12 widths
- 24 VDC motors
- Tapered tread rollers
- 30, 45, 60 and 90 degree curves



BETWEEN FRAME WIDTH	OVERALL FRAME WIDTH	INSIDE RADIUS	NUMBER OF ROLLERS				WEIGHT (LBS.)	
			30°	45°	60°	90°	30° & 60°	60° & 90°
13"	16"	24"	5	8	10	16	110	200
15"	18"		7	10	14	20	121	220
17"	20"						132	240
19"	22"						143	260
21"	24"						154	280
23"	26"						165	300
25"	28"	171					310	
27"	30"	48"	10	14	22	30	178	325
31"	34"						274	495
33"	36"						286	520
37"	40"						311	565
39"	42"						325	590

STANDARD SPECIFICATIONS

BED – 6 1/2 in. deep x 1 1/2 in. flange x 12 ga. powder coated steel channel with 2 1/2 in. dia. tapered to 1 11/16 in. dia. x 14 ga. galvanized rollers.

CURVES – 30, 45, 60 and 90 degree curves. 24 in., 32 1/2 in. or 48 in. radius dependent upon between frame widths.

MOTOR – 24 VDC flat motor mounted on inside of conveyor frame. Two motors within 60 and 90 degree curves, one motor within 30 and 45 degree curves.

MOTOR DRIVER CARD – One required for each motor

DRIVE/SLAVE BELTS – 3/16 in. dia. urethane belts from motor drive spool to rollers and roller to roller

POWER SUPPLY – Not included. Typically powered from straight section power supply.

BEARINGS – Tread rollers have grease packed ball bearings

CONVEYING SPEED – 50-174 FPM. Selectable on motor drive card.

OPTIONAL EQUIPMENT

FLOOR SUPPORTS – SMS Type floor supports are available with a wide range of adjustment. Specify top of belt or roller elevation. One support required at every bed joint and ends of conveyor. Holes in feet for lagging to floor. Knee braces included on SMS-7 support and above.

POWER SUPPLY – 5 AMP power supply is available for stand-alone curves (3 motors maximum)

SLAVED TANGENTS – 3 in. or 6 in. tangents slaved from curve with urethane O-ring belts

POWERED TANGENTS – 9 in., 12 in., 15 in., 18 in. or 21 in. tangents including one 24 VDC motor and motor driver card

GUIDE RAILS – Adjustable channel guide rail and fixed angle guide rails. Note: If product comes into contact with guide rails, product flow may be affected.

OTHER ACCESSORIES – Poly-tier supports, ceiling hangers. See accessory section.

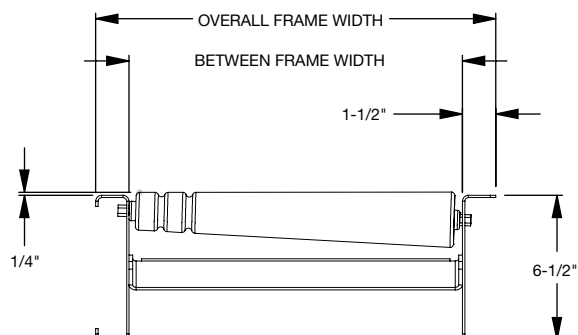
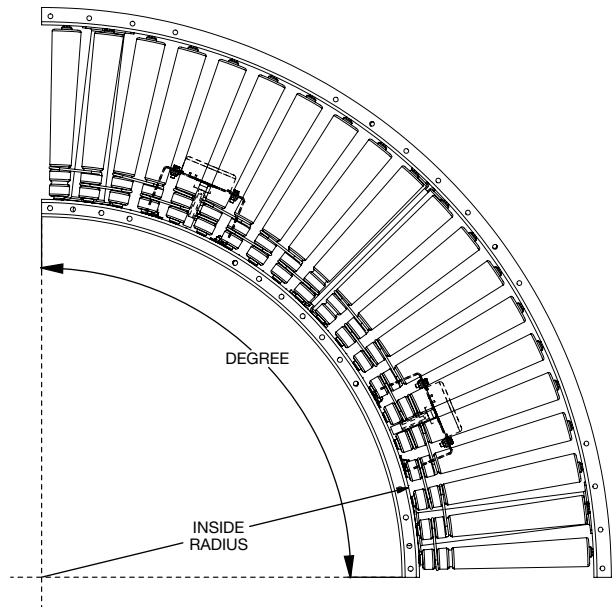

FMSS19T

FLAT MOTOR STRAIGHT SPUR (1.9 in. dia. x 16 ga. rollers)

The Model FMSS19T straight spurs are used to transfer product from one conveying line onto another and are suitable for merging or diverging applications.

- 12 widths
- 24 VDC motors
- 30 and 45 degree straight spurs

BETWEEN FRAME WIDTH	OVERALL FRAME WIDTH	NUMBER OF MOTORS		"A"		"B"		WEIGHT (LBS.)			
		30°	45°	30°	45°	30°	45°	30°	45°		
13"	16"	1	1	30"	21"	38"	29"	224	177		
15"	18"	2		54"	36"	41"	32"	233	184		
17"	20"					47"	35"	241	191		
19"	22"					50"	38"	249	198		
21"	24"					53"	41"	256	204		
23"	26"					56"	44"	262	210		
25"	28"					62"	47"	272	219		
27"	30"					65"	50"	278	225		
31"	34"					75"	48"	74"	56"	290	237
33"	36"							77"	59"	296	242
37"	40"							86"	65"	306	253
39"	42"							89"	68"	310	256

PLAN VIEW - 30° AND 45° STRAIGHT SPURS

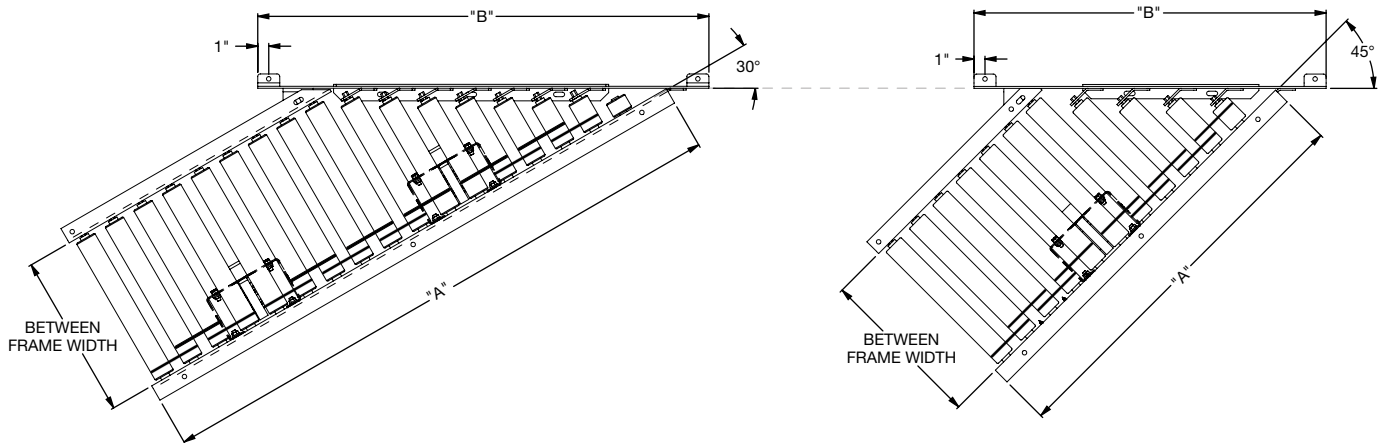

STANDARD SPECIFICATIONS

BED – 6 1/2 in. deep x 1 1/2 in. flange x 12 ga. powder coated steel channel with 1.9 in. dia. x 16 ga. galvanized tread rollers spaced on 3 in. centers.

SPURS – 30 and 45 degree spurs

MOTOR – 24 VDC flat motor(s) mounted on inside of conveyor frame

MOTOR DRIVER CARD – One required for each motor

DRIVE/SLAVE BELTS – 3/16 in. dia. urethane belts from motor drive spool to rollers and roller to roller

POWER SUPPLY – Not included. Typically powered from straight sections power supply.

BEARINGS – Tread rollers have grease packed ball bearings

CONVEYING SPEED – 50-174 FPM. Selectable on motor drive card.

CAPACITY – 75 lbs.

www.acgconveyors.com/partners/atlantis-conveyors/ • (866) 403-5232 (toll free) • sales@acgconveyors.com

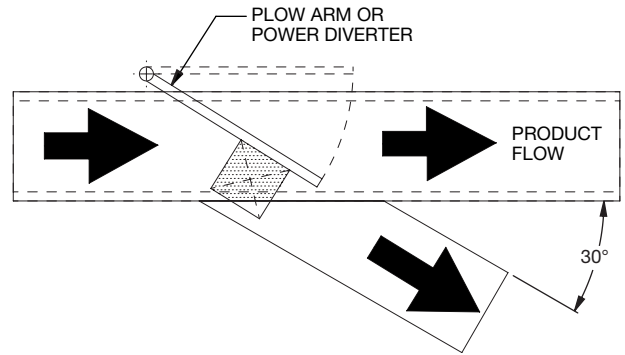
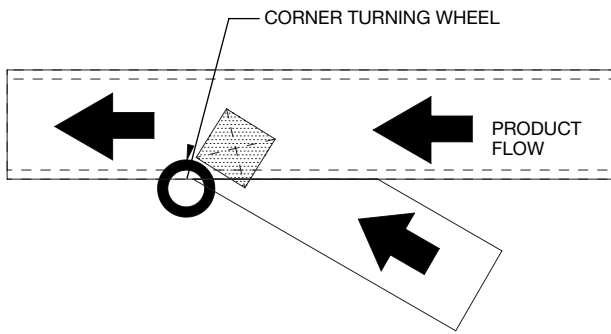

SPUR FLOW (SPECIFY)

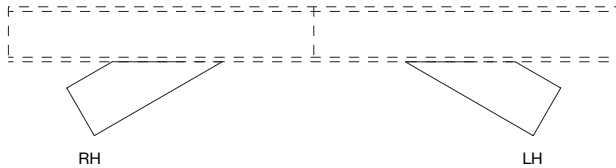

OPTIONAL EQUIPMENT

FLOOR SUPPORTS – SMS Type floor supports are available with a wide range of adjustment. Specify top of belt or roller elevation. One support required at every bed joint and ends of conveyor. Holes in feet for lagging to floor. Knee braces included on SMS-7 support and above.

POWER SUPPLY – 5 AMP power supply is available for stand-alone curves (3 motors maximum)

GUIDE RAILS – Adjustable channel guide rail and fixed angle guide rails. Note: If product comes into contact with guide rails, product flow may be affected.

OTHER ACCESSORIES – Poly-tier supports, ceiling hangers. See accessory section.