

BDS19M



BELT DRIVEN LIVE ROLLER CONVEYOR (1.9 in. dia. x 16 ga. rollers) (Minimum Pressure Accumulation)



The BDS19M live roller conveyor is ideal for transporting or accumulating cartons, boxes or totes. Its basic design eliminates complicated adjustments and allows a minimum of 2% back pressure.

- 12 widths
- Minimum pressure accumulation (2% back pressure)
- Fingertip pressure roller adjustments requiring no tools
- Reversible

OVERALL LENGTH	BED LENGTH	CONVEYOR WEIGHT (LBS.)											
		BETWEEN FRAME WIDTH											
		13"	15"	17"	19"	21"	23"	25"	27"	31"	33"	37"	39"
		OVERALL FRAME WIDTH											
6 IN. WIDE DRIVE BELT						8 IN. WIDE DRIVE BELT							
16"	18"	20"	22"	24"	26"	28"	30"	34"	36"	40"	42"		
10'	8'	385	416	448	479	509	551	581	612	679	720	771	803
15'	13'	521	552	596	637	679	733	744	816	908	950	1,033	1,077
20'	18'	657	688	744	797	849	915	967	1,020	1,137	1,190	1,295	1,351
25'	23'	793	824	898	956	1,019	1,097	1,160	1,224	1,366	1,430	1,557	1,625
30'	28'	929	960	1,040	1,115	1,189	1,279	1,353	1,628	1,595	1,670	1,819	1,899
35'	33'	1,065	1,096	1,188	1,274	1,359	1,461	1,546	1,632	1,824	1,910	2,081	21,73
40'	38'	1,201	1,232	1,336	1,433	1,529	1,643	1,739	1,836	2,053	2,150	2,343	2,447
45'	43'	1,337	1,368	1,484	1,592	1,699	1,825	1,935	2,040	2,282	2,390	2,605	2,721
50'	48'	1,473	1,504	1,632	1,751	1,869	2,007	2,125	2,244	2,511	2,630	2,867	2,995
55'	53'	1,609	1,640	1,780	1,910	2,039	2,189	2318	2,488	2,740	2,870	3,129	3,269
60'	58'	1,745	1,776	1,928	2,069	2,209	2371	2,511	2,652	2,969	3,010	3,391	3,543
65'	63'	1,886	1,912	2,076	2,228	2,379	2,553	2,704	2,856	3,198	3,350	3,653	3,817
70'	68'	2,017	2,048	2,224	2,387	2,549	2,735	2,897	3,060	3,427	3,590	3,915	4,091
75'	73'	2,153	2,184	2,372	2,546	2,719	2,917	3,090	3,264	3,656	3,830	4,177	4,365
80'	78'	2,289	2,320	2,520	275	2,889	3,099	3,283	3,468	3,885	4,070	4,439	4,639
85'	83'	2,425	2,456	2,668	2,864	3,059	3281	3,476	3,672	4,114	4,310	4,701	4,913
90'	88'	2,561	2,592	2,816	3,023	3,229	3,463	3,669	3,876	4,343	4,550	4,963	5,187
95'	93'	2,697	2,728	2,964	3,182	3,399	3,645	3,862	4,080	4,572	4,790	5,225	5,461
100'	98'	2,833	2,864	3,112	3,341	3,569	3,827	4,055	4,284	4,801	5,030	5,487	5,735

Note: Conveyor weights are based on 3" roller centers

STANDARD SPECIFICATIONS

BED – 6 1/2 in. deep x 1 1/2 in. flange x 12 ga. powder painted formed steel channel frame with 1.9 in. dia. x 16 ga. galvanized tread rollers spaced every 3 in. and 1.9 in. dia. x 16 ga. galvanized pressure rollers spaced every 6 in. Sections bolted together with butt couplings.

CROSS BRACING – Rods with turnbuckles are fastened to underside of bed to provide squaring adjustment and ensure correct product tracking. One set of turnbuckles are supplied for every 50 ft. of conveyor.

DRIVE – Mounted underneath near center of conveyor. Center drive unit is 16 in. wide for a 16 in. overall width conveyor and 18 in. wide for all other conveyor widths.

DRIVE BELT – Black Trackmate 120 EMB

DRIVE PULLEY – 8 in. dia. with 1 7/16 in. dia. shaft at bearings. Machine crowned and fully lagged.

TAIL PULLEY – 4 in. dia. with 1 1/8 in. dia. shaft at bearings, machine crowned.

TAKE-UP PULLEY – 6 in. dia. with 1 3/16 in. dia. shaft at bearings. Machine crowned.

TAKE-UP – Take-up in center drive which provides 16 in. of belt take-up.

SNUB IDLER – Adjustable 2 1/2 in. dia. rollers with grease packed ball bearings

RETURN IDLER – Adjustable 1.9 in. dia. roller with grease packed ball bearings

BEARINGS – Sealed, pre-lubricated, self-aligning, ball bearings on drive and tail pulleys. Grease packed ball bearings in tread and pressure rollers.

CONVEYING SPEED – Constant 65 FPM

SPEED REDUCTION – Sealed worm gear C-Face speed reducer. No. 50 roller chain to drive shaft.

MOTOR – 1/2 HP-230/460 -3 phase – 60 Hz totally enclosed fan cooled, energy efficient

CAPACITY – Maximum load per linear foot of conveyor 150 lbs. Total load not to exceed capacity in charts.

FPM	HP	BETWEEN FRAME WIDTH	LOAD CAPACITY (LBS.)			
			OVERALL LENGTH			
			10'	25'	50'	100'
35	1/2	13"-23"	1,500*	2,700	2,150	1,000
		25"-39"	1,500*	2,350	1,400	N/A
	1	13"-23"	1,500*	3,750*	5,500	4,300
		25"-39"	1,500*	3,750*	4,800	3,100
65	1/2	13"-23"	1,500*	1,200	600	N/A
		25"-39"	1,400	800	N/A	N/A
	1	13"-23"	1,500*	3,000	2,400	1,250
		25"-39"	1,500*	2,600	1,650	N/A
	2	13"-23"	1,500*	3,750*	6,100	4,800
		25"-39"	1,500*	3,750*	5,300	3,400
120	1	13"-23"	1,500*	1,350	750	N/A
		25"-39"	1,500*	950	100	N/A
	2	13"-23"	1,500*	3,300	2,705	1,550
		25"-39"	1,500*	2,950	2,000	100

* Limited by conveyor capacity

Note: Capacities shown assume a constant speed and maximum of 6 starts/stops per minute with no more than 30 starts/stops per hour.

SIDE VIEW

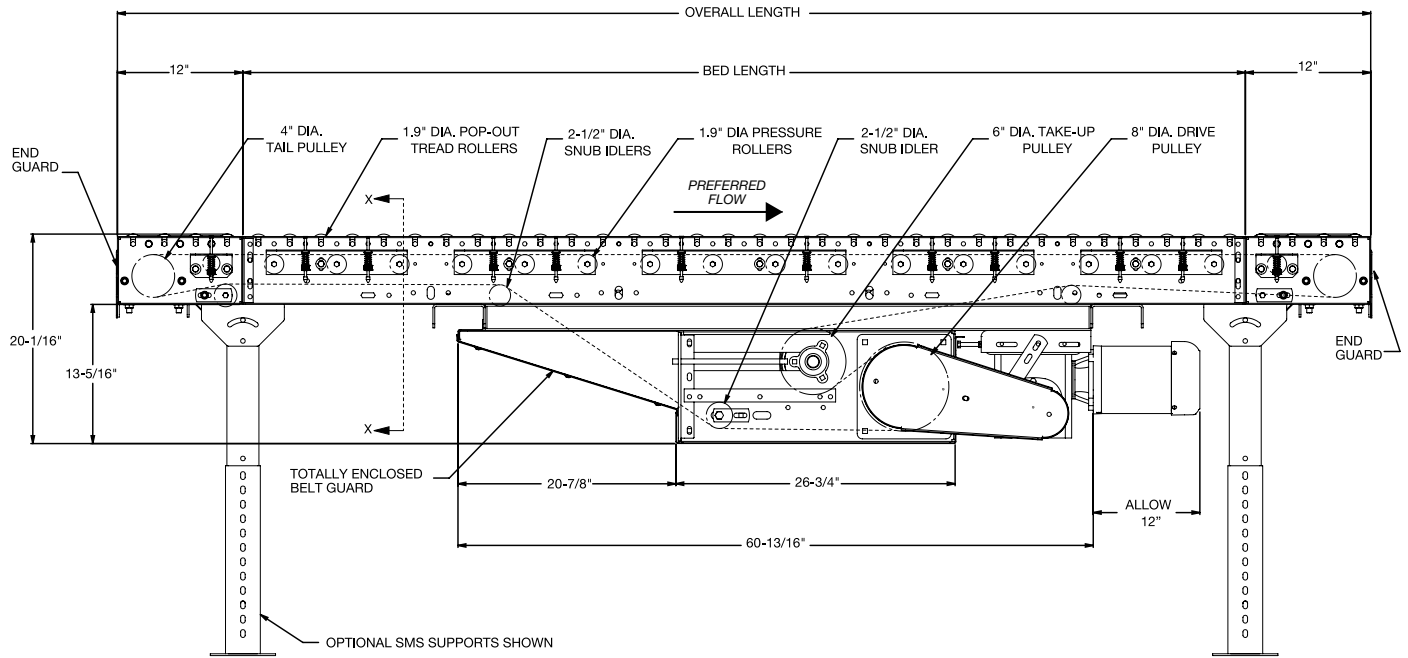

OPTIONAL EQUIPMENT

FLOOR SUPPORTS – SMS Type floor supports are available with a wide range of adjustment. Specify top of roller elevation. One support required at every bed joint and ends of conveyor. Holes in feet for lagging to floor. Knee braces supplied on SMS-7 support and above.

CONVEYING SPEED – Other constant and variable speeds. Note: Capacity and accumulation feature affected with speed change.

- Underhung and side mounted drives: 25 – 120 FPM in any increment
- Contact factory for speeds not listed

MOTORS – Inverter duty, premium energy efficient, single phase, brake motor and other characteristics. 2 HP maximum.

SIDE MOUNTED DRIVE – Motor reducer unit mounted to side of conveyor.

- Low elevation end drive with underside take-up: 12 1/4 in. TOR
- Center drive: 16 in. TOR

ROLLER CENTERS – Tread rollers spaced every 2 in or 4 in. (not available in 7 ft. 6 in. bed).

SLAVE KIT – To slave VBC19 curve from system end of belt conveyor.

GUIDE RAILS – Adjustable channel guide rail, fixed angle and channel guide rails. Note: If product comes into contact with guide rails, product flow will be affected.

OTHER ACCESSORIES – Poly-tier supports, ceiling hangers. See accessory section.

ELECTRICAL CONTROLS – One direction manual start switch, reversing drum switch, non-reversing and reversible IEC starters, push button stations, AC variable frequency drive.

SECTION VIEW X-X

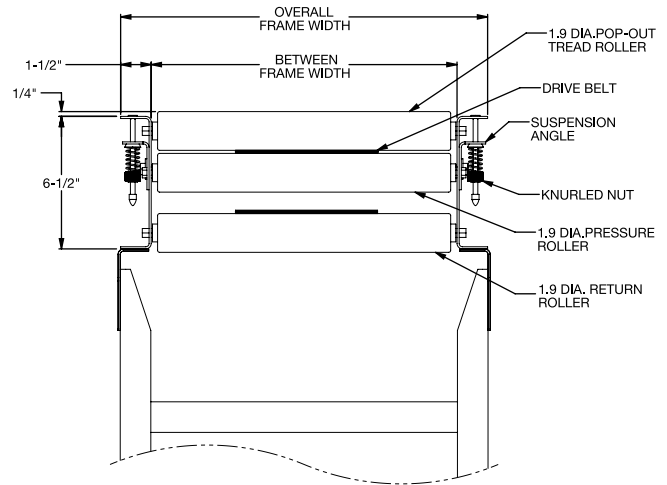

HOW IT WORKS:

The BDS19M is a minimum pressure conveyor meaning that product can be accumulated with a minimal amount of back pressure and horsepower. Tread rollers in contact with the product, are driven from underneath by the top surface of a drive belt running the length of the conveyor. Pressure rollers located under the belt push upward providing friction between the drive belt and the tread rollers. These pressure rollers are mounted in spring tensioned carriers that are easily adjusted with knurled finger nuts. Spring tension can be adjusted to achieve a back pressure equal to 2% of the accumulated live load.

