

ALBA TURNTABLE TOP

Model No. TT251160-3.75

Chain Driven Live Roller Conveyor Turntable Top - 3.75" Roller Centers RC-60 Roll to Roll Chains

<p>LENGTH: 2-1/2" diameter x 11 gauge wall, 11/16" hex axles, spring retained, two #60A15 sprockets, grease packed ball bearings</p> <p>FRAME: 6 @ 8.2# channel - driven side 4 @ 5.4# channel - non-driven side</p> <p>ROLLER CAPACITY: Bed rollers - 850 Lbs. each Drive rollers - 2,100 Lbs. each</p>	<p>SETTING: Rollers are set 1-7/8" low drive side and 1/4" high non-drive side</p> <p>ROLLERS: C-frame motor and gear reducer 230/460/3/60, RC-40 drive chain</p> <p>SPEEDS: 30, 45 or 60 FPM fixed</p>	<p>PAINT: Alba blue with safety yellow chain guards</p> <p>ELEVATION: 18" min. tor with pneumatic base and 17" tor with electric base</p> <p>OPTION: Transition roller stands</p>
---	--	--

WHEN ORDERING SPECIFY:

- MODEL#
- EFFECTIVE WIDTH
- HORSEPOWER
- SPEED
- BASE STYLE (ELECTRIC OR PNEUMATIC)
- TOP OF ROLLER ELEVATION
- OPTIONS

Please consult the factory with your application for proper drive sizing

AVAILABLE EFFECTIVE WIDTHS	
EFFECTIVE WIDTH	TABLE DIAMETER
44"	78"
48"	84"
52"	84"
54"	86"
60"	92"

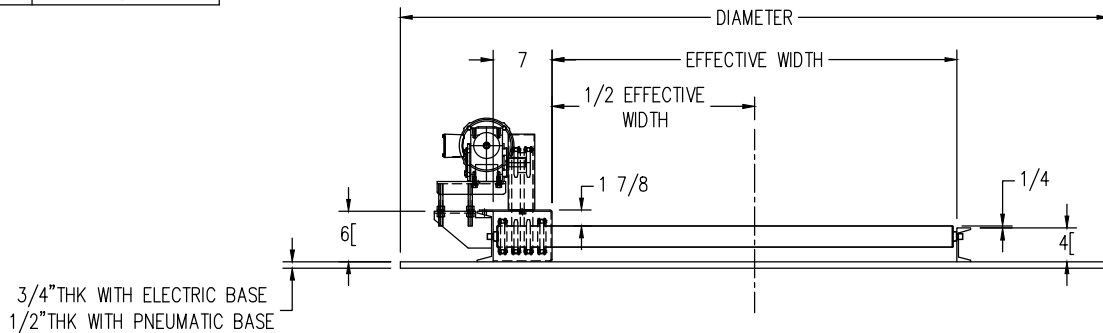
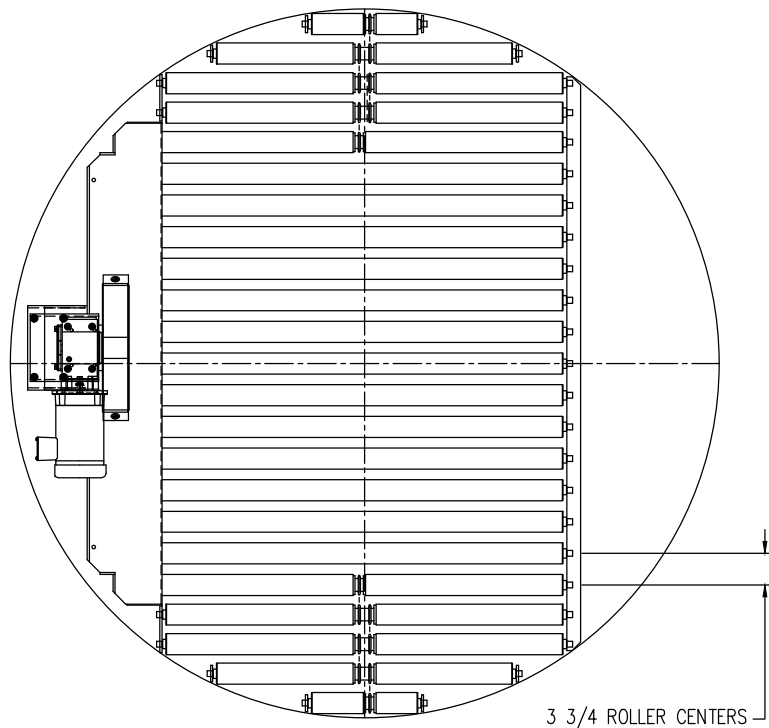

ALBA TURNTABLE CONVEYOR

Available Turntable Options:

- Turntable top diameters
- Conveyor widths
- Rollers
 - Galvanized tubing, zinc plated and stainless steel
 - Heavy duty and ABEC-1 roller bearings
- Drives
 - Motors
 - VFD rated motors
 - Voltages
 - Different brands and types of motors are available
 - Reducers
 - Different brands and types are available
- Pre-mounted devices
 - Operating voltages - 110 VAC (24 VDC standard)
 - Proximity Switches and cables
 - Filter/regulator w/ gauge
 - Photo-eyes and cables
 - Junction Boxes w/ drive motor and devices pre-wired
 - Slip ring assemblies to allow for continuous rotation of turntable top
- Paint and Finishes
 - Special paint colors
 - Epoxy paint and Steel-It epoxy paint
 - Hot dipped galvanized frames