

Dual Spiral Conveyors

“The Ultimate in Space Savings.”

The new Ryson Dual Track Spirals are the ultimate in space savings.

Two tracks operate within one spiral structure. Both tracks can go up or down, and can optionally be reversible.

Only one drive motor is required for each track, resulting in substantial savings in energy, controls and systems integration. The dual spiral conveyors build on the already proven Ryson Spiral Technology and are designed for low maintenance and long life. Ryson Spiral Conveyors need less floor space than conventional conveyors and are faster and more reliable than any elevator or lift.

Models with dual 8", 12", 16" or 20" wide slats are available. Some site assembly is required for models with 16" and 20" wide slats.

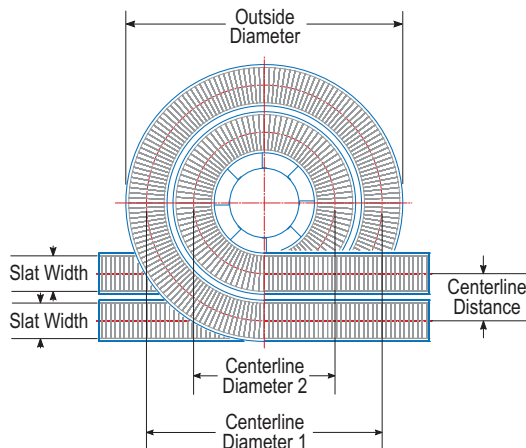
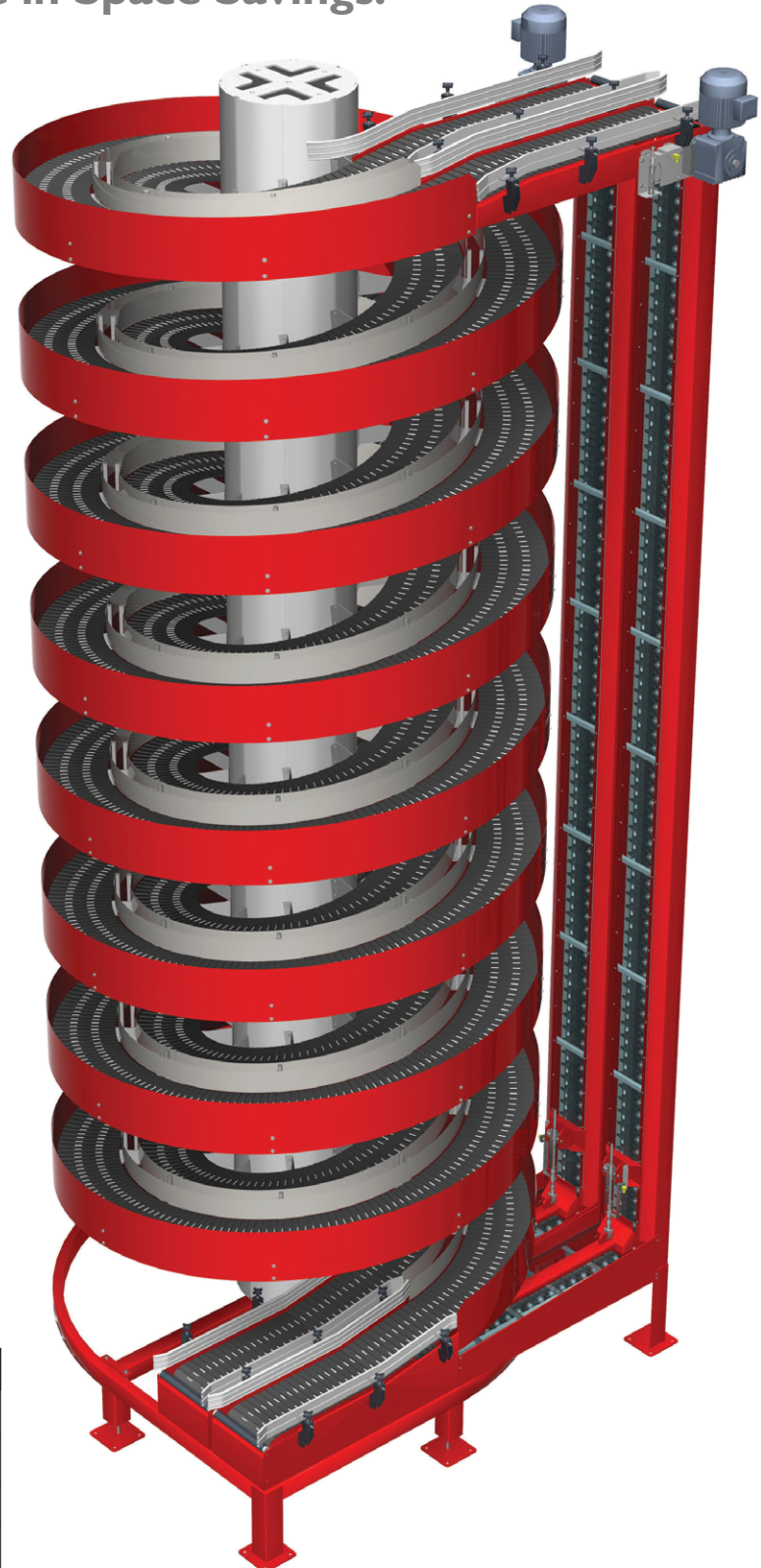

Type	Outside Diameter	Centerline Diameter 1	Centerline Diameter 2	Slat Width	Centerline Distance
1200-200/1800-200	6'-11" (2100)	5'-11" (1800)	3'-11" (1200)	8" (200)	1'-0" (300)
1200-300/2000-300	7'-11" (2400)	6'-6" (2000)	3'-11" (1200)	12" (300)	1'-4" (400)
1300-400/2300-400	9'-3" (2800)	7'-7" (2300)	4'-3" (1300)	16" (400)	1'-8" (500)
1600-500/2800-500	11'-2" (3400)	9'-2" (2800)	5'-3" (1600)	20" (500)	2'-0" (600)

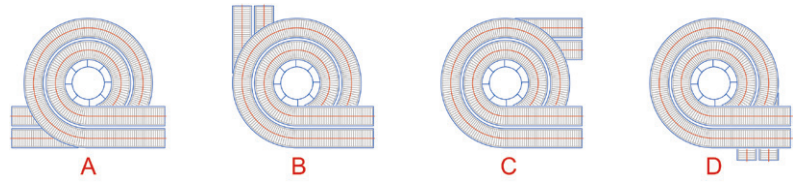

Modular Design:

An innovative modular design allows Ryson to customize with ease and modify in the field to accommodate emerging needs. All spirals are made to order and are available in 4 basic configurations (A, B, C and D), accommodating most requirements relating to the location of the in and out feed tangents. All configurations can operate up or down in a clockwise or counterclockwise rotation and custom configurations are available. The two tracks do not have to feed in and out of the spiral at the same elevations. Examples are shown below. Call us with your specific needs.

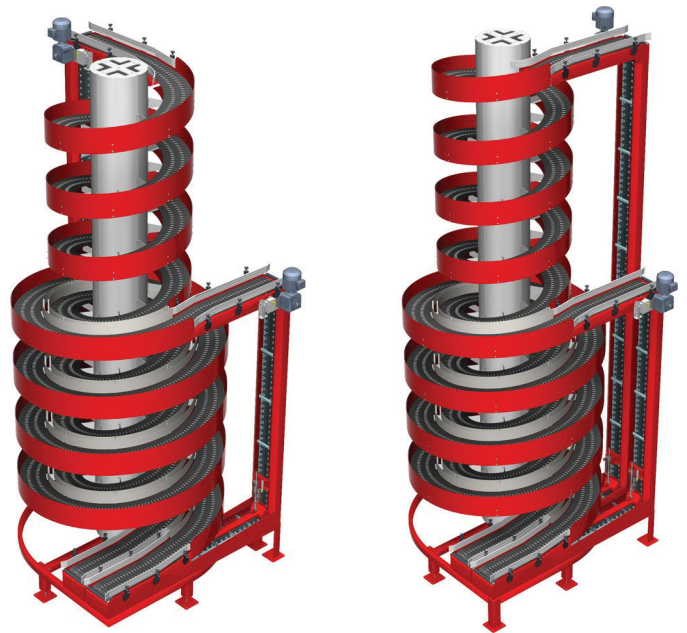

Controls and Integration:

Most of our spirals are shipped without controls because they normally integrate with an overall conveyor control system. The spirals always include an inverter duty gear motor and two proximity sensors, one for the automatic chain tensioner and one for the overload protection device. Refer to our website for controls options available from Ryson. A Variable Frequency Drive (VFD) is required for proper operation of the spirals.

All Ryson Spirals are thoroughly shop tested prior to shipment, but depend on proper integration with the overall conveyor system for optimum performance. Spiral integration instructions are available on www.ryson.com or give us a call to request a copy.

RYSON
INTERNATIONAL, INC

VERTICAL CONVEYING SOLUTIONS

Ryson is the number one Spiral Conveyor manufacturer in the USA.

For application assistance or more information, give us a call or visit www.ryson.com