

High Capacity Spirals

“A Spiral for the Tough Jobs.”

The new Ryson High Capacity Spirals are in response to our customers need to go higher and handle more weight.

The new spirals handle double the capacity of our regular spirals and ship in one piece which drastically reduce the time and cost of installation.

The load capacity is 75 lbs. per linear foot of conveyor for speeds up to 200 FPM. The total weight capacity in the spiral at any one time is 3200 lbs. Only one drive motor is required, resulting in substantial savings in energy, controls and system integration.

Ryson Spiral Conveyors need less floor space than conventional conveyors and are faster and more reliable than any elevator or lift.

Ryson Spirals are designed for low maintenance and long life. An innovative modular design allows Ryson to customize with ease and modify in the field to accommodate emerging needs.

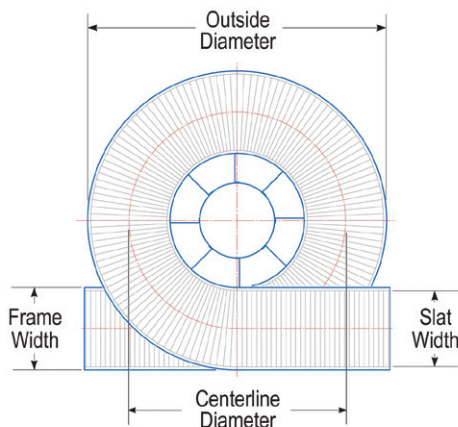

Type	Outside Diameter	Centerline Diameter	Slat Width	Frame Width
1700-400-HC	7'-3" (2200)	5'-7" (1700)	16" (400)	1'-7" (480)
1700-600-HC	7'-11" (2400)	5'-7" (1700)	24" (600)	2'-3" (680)

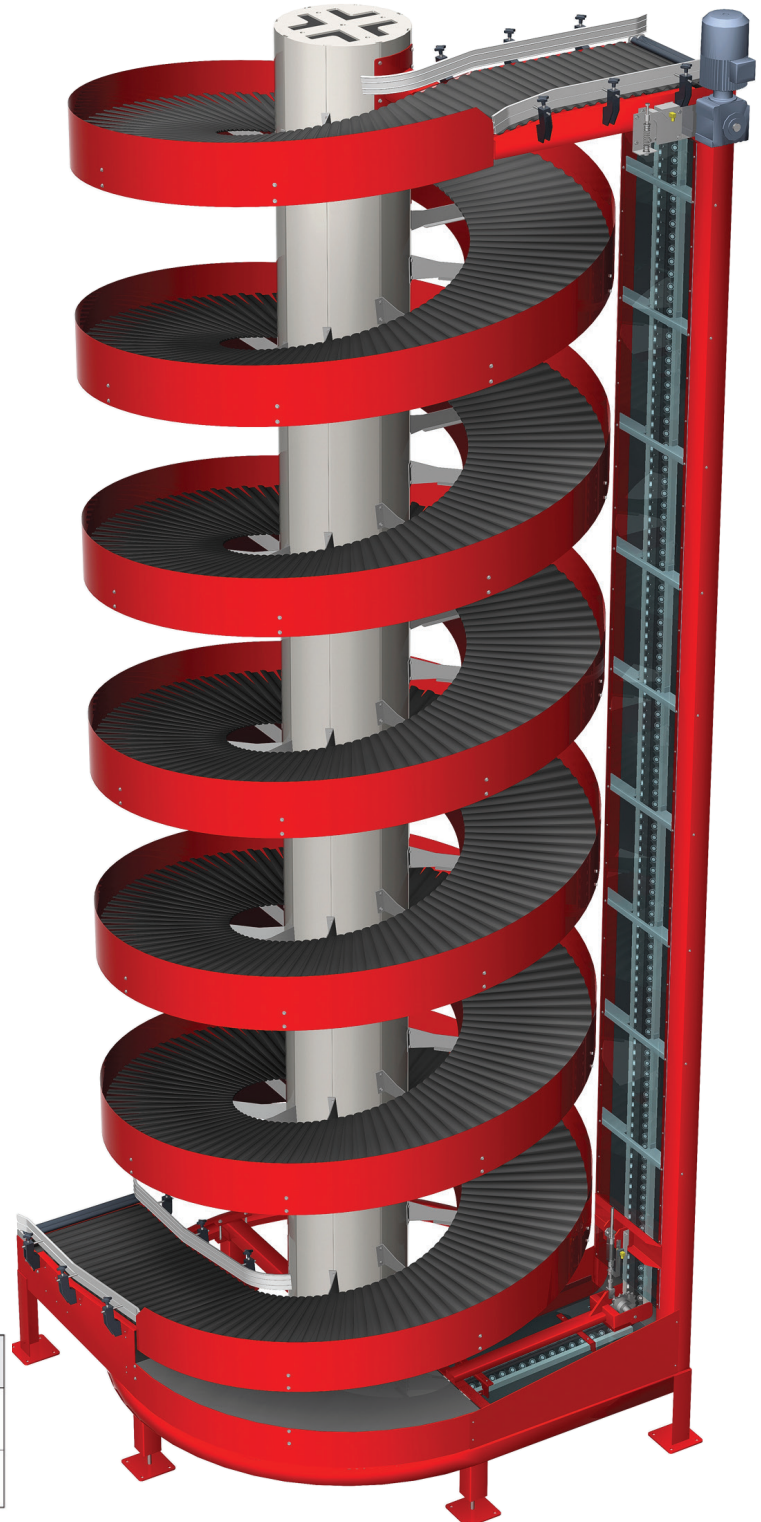



STANDARD CONFIGURATIONS

The high capacity spirals are available in 4 basic standard configurations (A, B, C and D) and will accommodate most requirements relating to the location of the in and out feed tangents. All configurations can operate up or down in a clockwise or counterclockwise rotation.

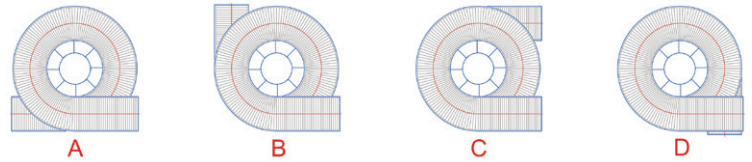

CUSTOM CONFIGURATIONS

The position of the infeed tangent on up spirals and the outfeed tangent on down spirals can be customized to meet specific layout requirements. This is possible for all standard configurations. The following depict samples of common customizations:

- **C-EX** configuration matches the centerline of the top and bottom conveyor centerlines. Centerline offsets can also be accommodated.
- **B-MA** is an example of modified in or outfeed angle. The modified angle is normally 45 or 30 degrees, but other angles can be provided.
- **A-EX** show extended in or outfeed tangents which can be straight or curved and can accommodate centerline off-sets.

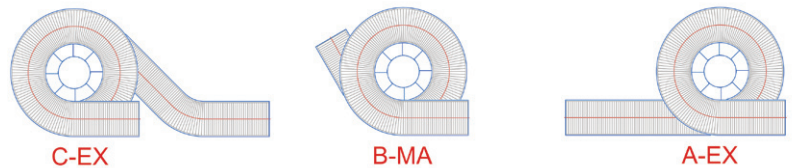

CONTROLS

Most of our spirals are shipped without controls because they are normally integrated into an overall conveyor control system. The spirals always include an inverter duty gear motor and two proximity sensors, one for the automatic chain tensioner and one for the overload protection device.

A Variable Frequency Drive (VFD) is required for the proper operation of the spiral. Ryson offers several controls options including :

- Stand alone control panel with interface capabilities
- Proximity sensors pre-wired to a central junction box
- Pre-wired motor disconnect
- Pre-wired missing slat detection sensors

INTEGRATION

All Ryson Spirals are shop tested prior to shipment, but optimal performance depends on proper integration with the overall conveyor system. Please refer to the Ryson Spiral integration instructions available on www.ryson.com, or call 757 898 1530 to request a copy.

RYSON
INTERNATIONAL, INC

VERTICAL CONVEYING SOLUTIONS

Ryson is the number one Spiral Conveyor manufacturer in the USA.
For application assistance or more information, give us a call or visit www.ryson.com