

PACLINE™

OVERHEAD CONVEYORS

ISO 9001

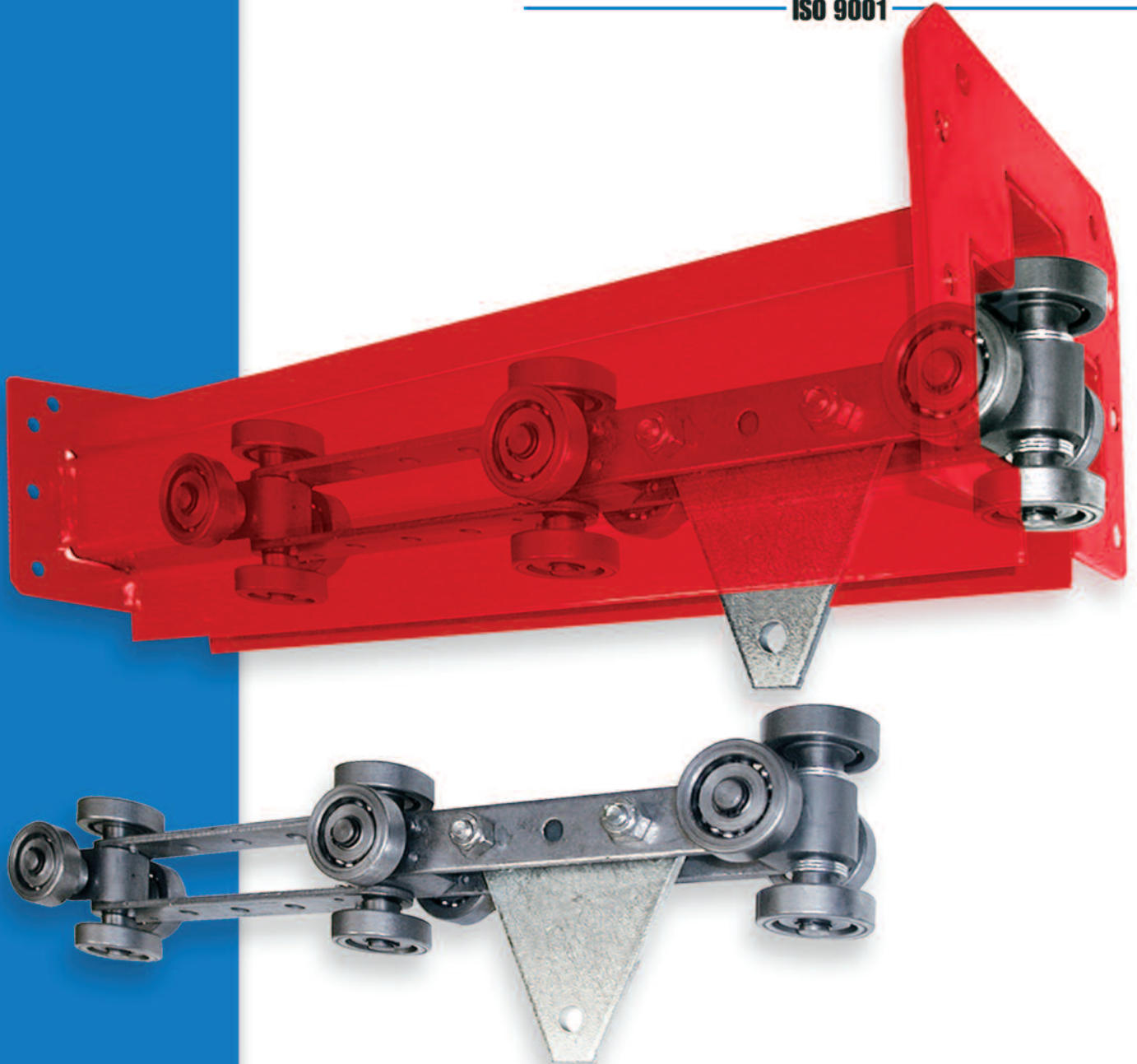

PAC-MAX™

Heavy Duty Conveyor

Compact & Stable • High Capacity • Modular Components
Use Inverted or Slot Sideways • Bolted Assembly

PAC-MAX™ (Model S-60) Specifications

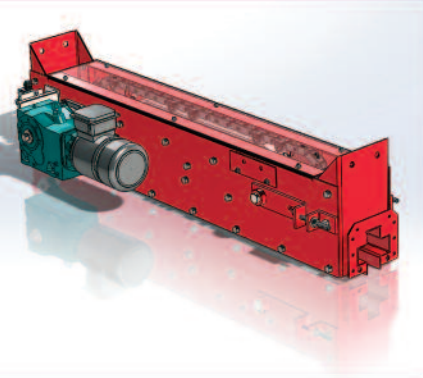

PAC-MAX Drive

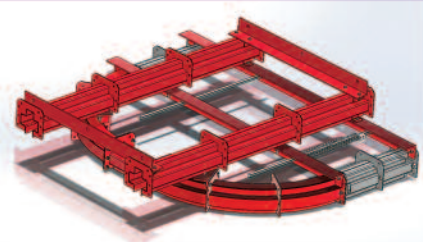

PAC-MAX Take-Up

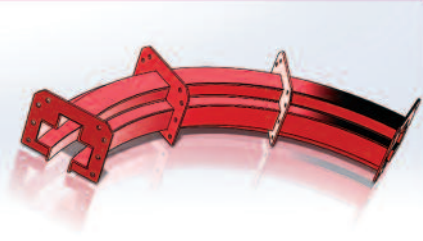

PAC-MAX Curve

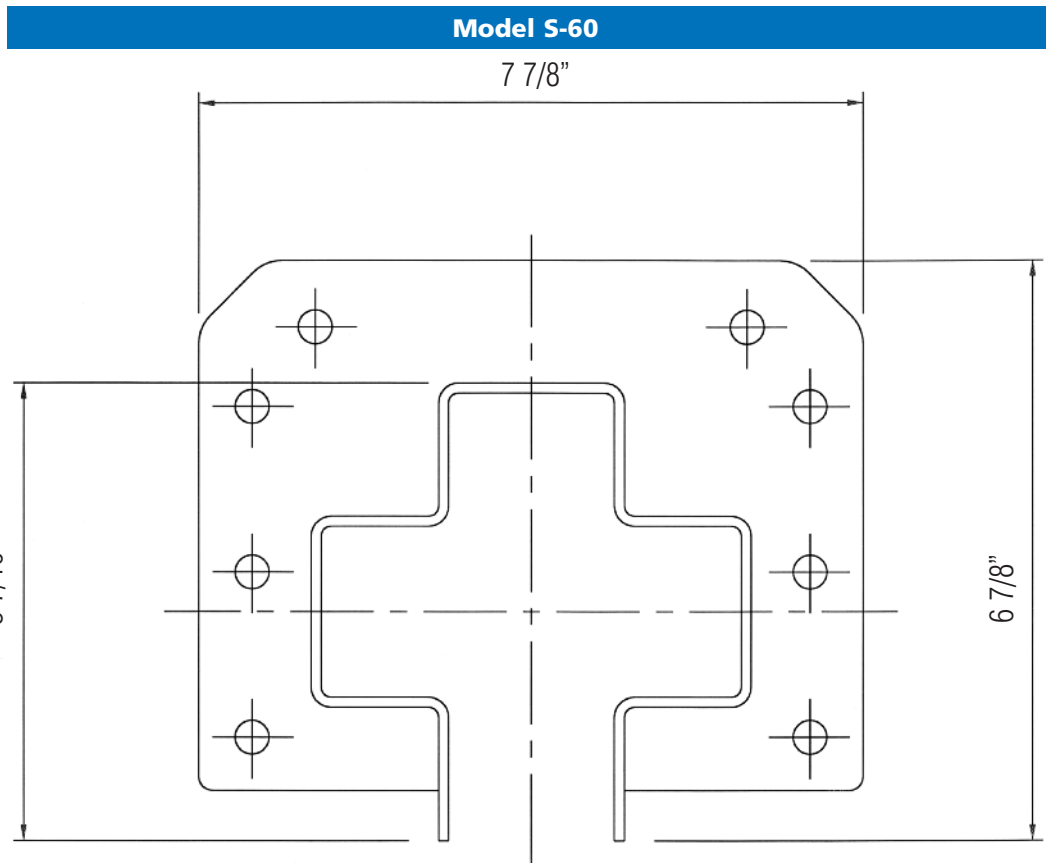

S-60	
Maximum Load Per Pendant	200 lbs.
Maximum Drive Pull	2,000 lbs.
Chain Breaking Load	15,000 lbs.
Max Chain Length Per Drive	1,000 ft.
Chain Friction Co-efficient	2.5%
Pendant Centers	16 inches
Minimum Horizontal Curve Radius	30 inches
Minimum Vertical Curve Radius	48 inches
Maximum Drive Speed	45 F.P.M.
Maximum Incline Angle	90 degrees
Capable for Inverted or Sideloaded*	yes

* Load capacity is derated for inverted / sideloaded orientation

Distributed by:

PACLINELINE™
OVERHEAD CONVEYORS
WWW.PACLINELINE.COM

1-800-955-8860 • sales@pacline.com