

BL Portable Folding Booster Belt Conveyor

The longer Model BL can be used to convey material from one floor to another. . . or to a balcony area. Its long bed can also extend far into a truck, thereby minimizing the distance for loading or unloading the conveyor.

- Reversible
- Bed Section Folds
- 14" Wide Roughtop Belt
- Self-powered Raising Device

SIZE TO ORDER	Overall Length "A"	Angle of Incline	"B"	"H"	"E"	"L"	Weights (Lbs.)
20'	20'-9"	13°	68"	5'-7"	9'-9"	20'-4"	930
		25°		9'-9"	8'-3"	18'-11"	
		30°		11'-4"	7'-6"	10'-1"	
		45°		16'-0"	4'-1"	14'-8"	
22'	22'-9"	13°	92"	6'-1"	11'-9"	22'-4"	990
		25°		10'-7"	10'-2"	20'-9"	
		30°		12'-4"	9'-3"	19'-10"	
		45°		17'-6"	5'-6"	16'-1"	

All weights in catalog are conveyor weights only. Accessories, crating, etc., are not included.

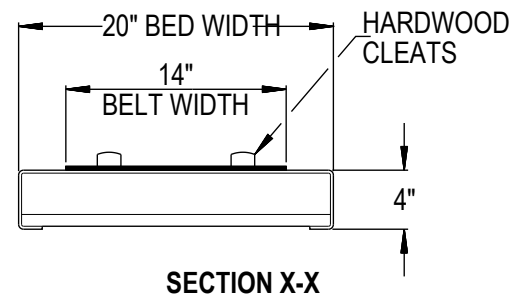
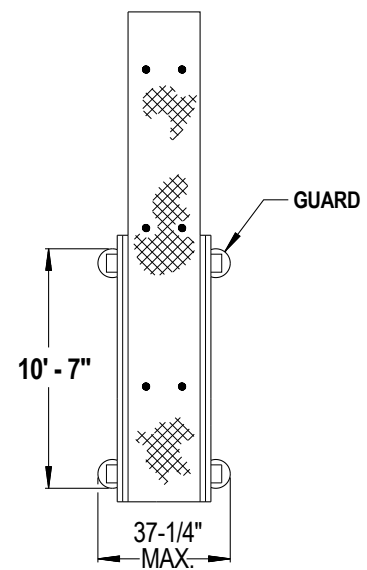
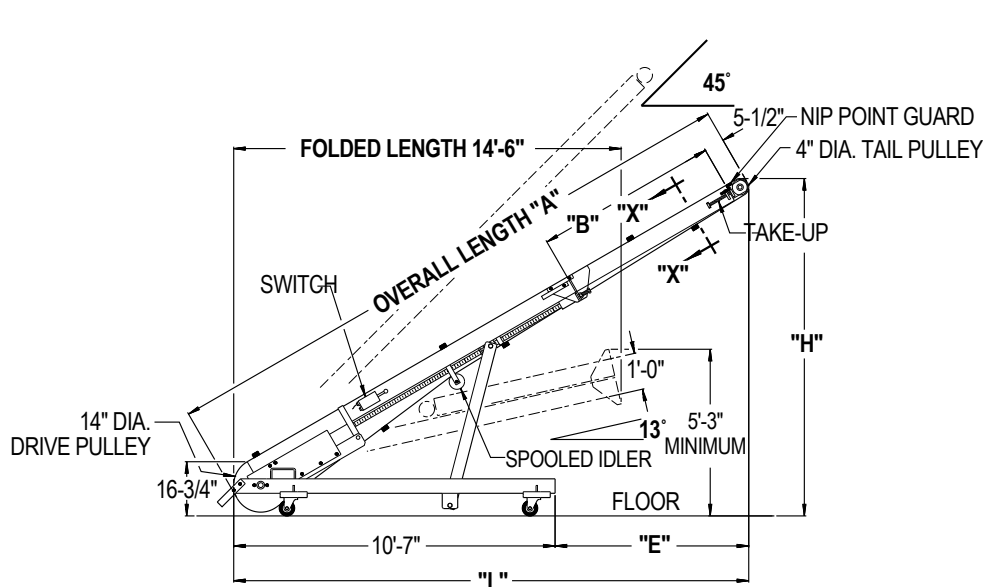

• STANDARD SPECIFICATIONS

BELT—14 in. wide Black Trackmate 120 Roughtop with PVC cover. Clipper lacing.

CLEATS—Two 1 ½ in. dia. x 1 in. high hardwood cleats, fastened to belt with ⅝ in. elevator bolts spaced every 60 in.

BED—4 in. deep x 20 in. wide x 12 ga. powder painted formed steel slider bed. Bed is hinged for storage purposes (see drawing).

HINGES—To fold bed to shorter length for storage. Screw adjustment insures alignment of bed. Exclusive link (breathing feature) prevents damage of belt.

INCLINE—Adjustable from 13° to 45° with conveyor motor powered screw raising device. Safety nut prevents rapid release of bed in case of overloading.

BASE—Welded steel base (see drawing for dimensions).

CASTERS—6 in. dia. steel swivel casters with corner guards.

DRIVE PULLEY—14 in. dia. with 1 in. dia. removable shaft. Crowned and fully lagged.

TAIL PULLEY—4 in. dia. with 1 in. dia. shaft at bearings, machine crowned.

RETURN IDLER—4 in. dia. spooled idler to provide clearance for cleats. Pre-lubricated ball bearings.

TAKE-UP—Take-ups provided at tail pulley. Provides 4 in. of belt take-up.

BEARINGS—Sealed, pre-lubricated, self-aligning, ball bearings on tail pulley. Re-lube roller bearings on drive pulley.

SPEED REDUCTION—Sealed worm gear speed reducer driven by V-belt. No. 50 roller chain to drive pulley.

MOTOR—1 HP—115/230V—1 Ph. 60 Hz. Totally Enclosed. Wired for 115 volt.

ELECTRICAL CONTROLS—Reversing drum switch with 20 ft. power cord and plug.

BELT SPEED—Constant 65 FPM.

CAPACITY—300 lbs. total distributed load, 150 lbs. unit load at 65 FPM.

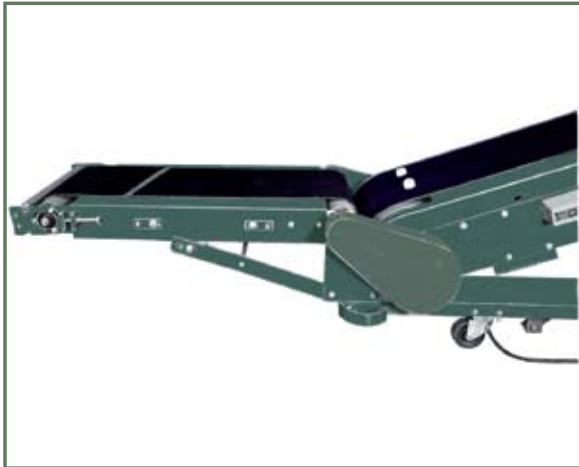

LOWER POWERED FEEDER



TROUGHING ATTACHMENT WITH HOPPER

• OPTIONAL EQUIPMENT

RUBBER CASTERS—6 in. dia. rubber swivel casters in place of steel casters.

FLOOR LOCKS—Two foot operated toggle floor locks mounted on one side of conveyor base to prevent unit from moving when in operation.

GRAVITY CONVEYOR BRACKET—Adjustable bar for connecting wheel or roller gravity conveyor (discharge only).

LOWER GRAVITY FEEDER—2 ft. long x 18 in. wide (1 ½ SW-18-36) includes adjustable tubular support and gravity conveyor bracket.

UPPER GRAVITY FEEDER—2 ft. long x 18 in. wide (3 SW-18-18) includes adjustable tubular support and gravity conveyor bracket.

LOWER POWERED FEEDER—Chain type driven from drive pulley. 43 in. long belt feeder section includes adjustable tubular support and gravity conveyor bracket.

GUARD RAILS—Channel type, adjustable vertically (specify fixed horizontal width). Not foldable with guard rails.

TROUGHING ATTACHMENT—Flat steel supports under belt form trough for handling loose material. Hopper available. Not foldable with troughing attachment.

REMOTE SWITCH CONTROL—Rod running length of conveyor to operate reverse drum switch from both ends. Switch regularly furnished on right side (when standing at drive pulley and looking up toward tail pulley).

MOTORS—2 HP 230/1/60.