

# R

## Aluminum Portable Folding Belt Conveyor

The Model R, besides being extremely convenient (it can be folded in half), is also extremely versatile. For example, its conveying uses include: truck, loft or freight car, floor-to-floor, stairway, as well as its use as a portable booster with a wheel or roller conveyor. It is also suitable for bag handling, bag and carton stacking, and moving cartons, cases, and boxes.

- Folding Aluminum Bed
- Roughtop Belt
- Electrical Controls
- Reversible



ADJUSTMENT CHART FOR 10' TO 21' LONG UNITS

SIZE TO ORDER	Angle of Incline	D = 7"			SIZE TO ORDER	Angle of Incline	D = 18"			SIZE TO ORDER	Angle of Incline	D = 31"		
		Less Roller Carriage					With Roller Carriage					With Roller Carriage		
		"E"	"F"	"G"			"E"	"F"	"G"			"E"	"F"	"G"
10'	11°	2'-5"	9'-10"	1'-8"	10'	3°	2'-0"	10'-0"	1'-10"	10'	0°	2'-7"	10'-1"	2'-1"
	25°	4'-6"	9'-1"	1'-2"		25°	5'-6"	9'-2"	1'-5"		25°	6'-6"	9'-1"	2'-0"
	30°	5'-3"	8'-9"	0'-11"		30°	6'-3"	8'-7"	1'-3"		27°	6'-11"	8'-11"	2'-0"
	43°	7'-0"	7'-6"	0'-1"		36°	7'-1"	8'-2"	1'-0"		-	-	-	-
11 1/2'	11°	2'-9"	11'-5"	3'-3"	11 1/2'	3°	2'-1"	11'-7"	3'-5"	11 1/2'	0°	2'-7"	11'-7"	3'-9"
	25°	5'-3"	10'-7"	2'-7"		25°	6'-3"	10'-7"	2'-10"		25°	7'-3"	10'-7"	3'-6"
	30°	6'-1"	10'-2"	2'-4"		30°	7'-1"	10'-2"	2'-8"		27°	7'-8"	10'-5"	3'-5"
	43°	8'-1"	8'-8"	1'-4"		36°	8'-1"	9'-6"	2'-4"		-	-	-	-
13'	11°	3'-0"	12'-11"	2'-10"	13'	3°	2'-2"	13'-0"	3'-0"	13'	0°	2'-7"	13'-1"	3'-3"
	25°	5'-10"	11'-11"	2'-5"		25°	6'-11"	12'-0"	2'-11"		25°	7'-11"	11'-11"	4'-0"
	30°	6'-10"	11'-5"	2'-3"		30°	7'-10"	11'-5"	2'-10"		27°	8'-4"	11'-9"	4'-0"
	43°	9'-2"	9'-9"	1'-8"		36°	9'-0"	10'-9"	2'-10"		-	-	-	-
15'	11°	3'-5"	14'-10"	4'-10"	15'	3°	2'-3"	15'-0"	5'-0"	15'	0°	2'-7"	15'-1"	5'-3"
	25°	6'-9"	13'-9"	4'-2"		25°	7'-9"	13'-9"	4'-8"		25°	8'-9"	13'-9"	5'-9"
	30°	7'-10"	13'-2"	3'-11"		30°	8'-10"	13'-2"	4'-7"		27°	9'-3"	13'-6"	5'-9"
	43°	10'-6"	11'-3"	3'-2"		36°	10'-2"	12'-4"	4'-5"		-	-	-	-
17'	10°	3'-6"	16'-10"	5'-9"	17'	3°	2'-5"	17'-0"	6'-0"	17'	0°	2'-7"	17'-1"	6'-3"
	25°	7'-6"	15'-6"	5'-3"		25°	8'-7"	15'-6"	5'-11"		25°	9'-7"	15'-6"	7'-5"
	30°	8'-10"	14'-10"	5'-1"		30°	9'-10"	14'-10"	5'-10"		-	-	-	-
	38°	10'-9"	13'-7"	4'-9"		36°	11'-3"	13'-11"	5'-8"		-	-	-	-
19'	10°	3'-9"	18'-10"	7'-9"	19'	3°	2'-6"	19'-0"	8'-0"	19'	0°	2'-7"	19'-1"	8'-3"
	25°	8'-5"	17'-3"	7'-1"		25°	9'-5"	17'-4"	7'-9"		23°	9'-11"	17'-7"	9'-0"
	30°	9'-10"	16'-7"	6'-10"		30°	10'-10"	16'-7"	7'-8"		-	-	-	-
	38°	12'-0"	15'-2"	6'-3"		-	-	-	-		-	-	-	-
21'	8°	3'-6"	20'-11"	9'-0"	21'	2°	2'-3"	21'-0"	9'-3"	21'	0°	2'-7"	21'-1"	9'-6"
	25°	9'-3"	19'-1"	8'-4"		25°	10'-3"	19'-2"	9'-2"		23°	10'-8"	19'-5"	10'-7"
	30°	10'-9"	18'-4"	8'-1"		30°	11'-10"	18'-3"	9'-1"		-	-	-	-
	37°	12'-11"	17'-0"	7'-10"		-	-	-	-		-	-	-	-

1 Week Availability

### SECTION X-X

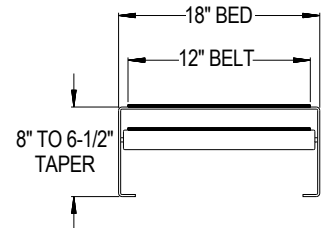

### SECTION Y-Y

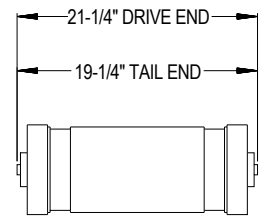

### FOLDED MODEL "R"

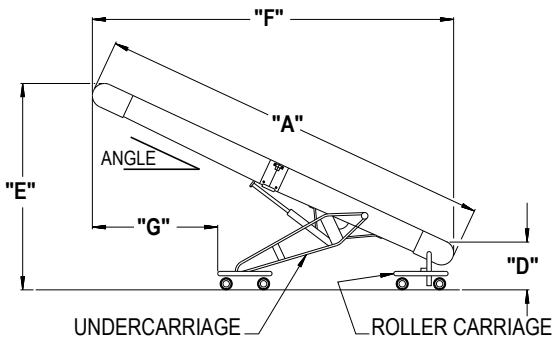
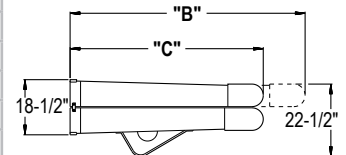

SIZE TO ORDER	Motor H.P.	Overall Length "A"	"B"	"C"	Weights (Lbs.)
10'	1/2	10'-1"	5'-0 1/2"	5'-0 1/2"	175
11 1/2'	1/2	11'-7"	6'-6 1/2"	5'-0 1/2"	190
13'	1/2	13'-1"	6'-6 1/2"	6'-6 1/2"	205
15'	1/2	15'-1"	8'-6 1/2"	6'-6 1/2"	225
17'	1/2	17'-1"	8'-6 1/2"	8'-6 1/2"	245
19'	1	19'-1"	10'-6 1/2"	8'-6 1/2"	270
21'	1	21'-1"	10'-6 1/2"	10'-6 1/2"	285

All weights in catalog are conveyor weights only. Accessories, crating, etc., are not included.

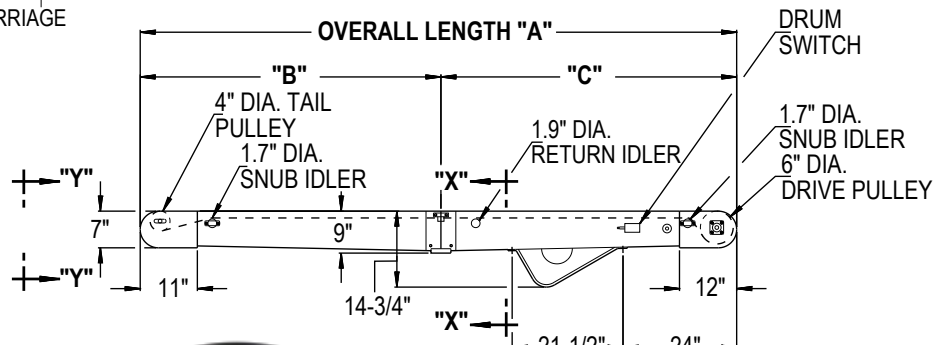

## • STANDARD SPECIFICATIONS

**BELT**—12 in. wide Black Trackmate 120 Roughtop with PVC cover. Clipper lacing.

**BED**—18 in. wide x .080 aluminum, 6061-T6 heat treated, reinforced.

**DRIVE PULLEY**—6 in. dia. with  $\frac{3}{4}$  in. dia. shaft. Machine crowned and fully lagged.

**TAIL PULLEY**—4 in. dia. with 1 in. dia. shaft at bearings, machine crowned.

**SNUB IDLER**—Adjustable 1.7 in. dia. pre-lubricated ball bearings.

**RETURN IDLER**—Adjustable 1.9 in. dia. pre-lubricated ball bearings.

**TAKE-UP**—Take-ups provided at tail pulley. Provides 4 in. of belt take-up.

**BEARINGS**—Sealed, pre-lubricated ball bearings on drive and tail pulleys.

**SPEED REDUCTION**—4-step jackshaft V-belt and No. 40 roller chain.

**MOTOR**—For HP see chart, 115/230V—1 Ph. 60 Hz. totally enclosed and wired for 115 volt.

**ELECTRICAL CONTROLS**—Reversing drum switch with power cord and plug mounted on side shown on drawing. Specify if other side desired.

**BELT SPEED**—Constant 65 FPM.

**CAPACITY**—300 lbs. total distributed load, 150 lbs. unit load at 65 FPM.



GRAVITY CONVEYOR BRACKET



ROLLER CARRIAGE AND UNDERCARRIAGE



LOWER POWERED FEEDER

## • OPTIONAL EQUIPMENT

**CLEATED BELT**—Two 1  $\frac{1}{2}$  in. dia. x 1 in. high hardwood cleats, fastened to belt with  $\frac{5}{16}$  in. elevator bolts spaced every 60 in. Requires gear reducer drive and spooled idlers.

**BELT SPEED**—Other constant and variable speeds. Requires gear reducer drive. NOTE: Capacity affected with speed change.

**RUBBER WHEELS**—Two 6 in. dia. x 2 in. wide with  $\frac{5}{8}$  in. dia. shaft.

**STAND WITH RUBBER WHEELS**—6 in. dia. x 2 in. wide wheels (with locks) mounted on adjustable tubular stand, 17 in. to 36 in. top of belt.

**UNDERCARRIAGE**—25 in. wide tubular steel frame with hydraulic adjustment mounted on support with 4 in. dia. steel swivel casters. See drawing and adjustment chart. Not available on 19 ft. & 21 ft.

**ROLLER CARRIAGE**—25 in. wide tubular steel support with 4 in. dia. steel swivel casters. See drawing and adjustment chart.

**FLOOR SUPPORTS**—Adjustable steel channel with knee braces. RSR type.

**GRAVITY CONVEYOR BRACKET**— $\frac{1}{2}$  in. dia. rod for connecting wheel or roller conveyor.

**LOWER GRAVITY FEEDER**—2 ft. long x 18 in. wide (1  $\frac{1}{2}$  SW-18-36) includes adjustable tubular support and gravity conveyor bracket.

**UPPER GRAVITY FEEDER**—2 ft. long x 18 in. wide (3 SW-18-18) includes adjustable tubular support and gravity conveyor bracket.

**LOWER POWERED FEEDER**—Chain type driven from drive pulley. 2 ft. 6 in. long belt feeder section includes adjustable tubular support and gravity conveyor bracket.

**GUARD RAILS**—Channel type, adjustable vertically and horizontally.

**STAIRWAY WALL BRACKETS**—Hinged brackets bolt to bed section and wall. Adjustable leg to rest on floor or step. Hook to hold conveyor close to wall when not in use.

**TROUGHING ATTACHMENT**—Flat steel supports under belt form trough for handling loose material. Hopper available. Not foldable with troughing attachment.

**STAINLESS STEEL BED COVER**—18 ga. stainless steel skin (for ice house application).

**SELF-CLEANING DRIVE & TAIL PULLEYS**—Crowned and ribbed to prevent clogging under belt.

**GEAR REDUCER DRIVE**—Sealed worm gear speed reducer driven by motor with V-belt. Drive is bolted to bottom of bed. (Standard motor support and guard not available.) Affects mounting of other options. Consult factory.

**REMOTE SWITCH CONTROL**—Rod running length of conveyor to operate reverse drum switch from both ends. Switch regularly furnished on side shown on drawing. Specify if required on other side.

**MOTORS**—1 HP maximum.