

DCEZ-83

Drag Chain Conveyor

The Model DCEZ-83 is a three strand drag chain conveyor designed to handle pallets. With EZLogic® Zone Controller, pallets are accumulated with zero pressure reducing the possibility of collision that may result in product damage.

- 3 Strand Design
- EZLogic® Accumulation System (Diffuse)
- 10 Widths
- Modular Assembly
- Adjustable DC3S and DCDS-Type Floor Supports Available



U.S. Patent Numbers
5,862,907 • 7,243,781 • 7,591,366
Other Patents Pending.



OVERALL LENGTH "A"	FRAME WIDTH	50 1/2"	56 1/2"	62 1/2"	68 1/2"	74 1/2"	80 1/2"	86 1/2"	92 1/2"	98 1/2"	104 1/2"
	STRAND CENTERS	24"	27"	30"	33"	36"	39"	42"	45"	48"	51"
12'	WEIGHTS (Lbs.) based on 60" Frame Lengths	1255	1305	1355	1405	1455	1505	1555	1605	1655	1705
Per Foot Weight		77	80	83	86	89	92	95	98	101	104

All weights in catalog are conveyor weights only. Accessories, crating, etc., are not included.

HOW IT WORKS

The conveyor is made up of drive, intermediate and tail sections on which three strands of #80 single-pitch chain travel. Each strand is a continuous loop and driven by a common drive shaft. Hytrol's EZLogic® Zone Controller sense product presence and control the accumulation and release of product from the zones. To accumulate products accumulation lift pads are activated which lift the product off of chain strands.

IMPORTANT NOTE:

Do not operate DCEZ in sleep or slug mode.

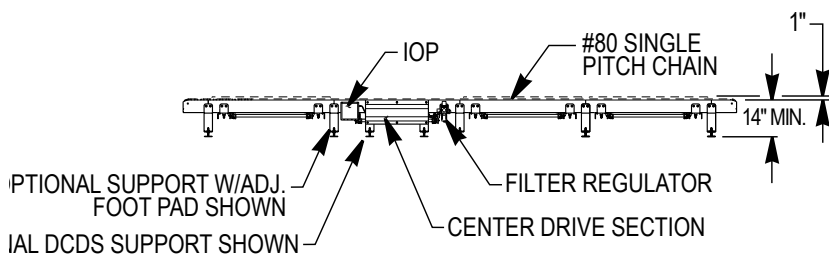
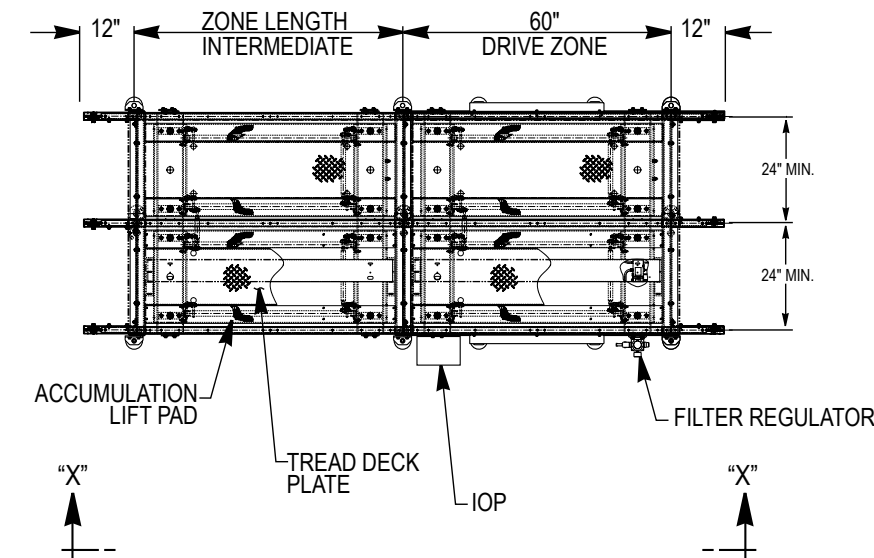

VIEW X-X



• STANDARD SPECIFICATIONS

CHAIN – #80 single pitch conveyor chain (straight sidebar).

CHAIN GUIDE – UHMW polyethylene.

FRAME – 6 in. x 4 ga. powder painted formed steel angle with 2 in. x ¼ in. wall, chain support tube. 4 ga. formed coupling channels located at infeed and discharge ends of each module.

DRIVE SPROCKETS – Hardened #80 with 1 ½ in. dia. steel shaft.

BEARINGS – Sealed, pre-lubricated, self aligning, ball bearings on drive.

ACCUMULATION ZONES – 36 in., 42 in., 48 in., 54 in., 60 in., and 66 in. long intermediate sections with EZLogic® Accumulation (Diffuse). Contact factory for other lengths. (Drive Section minimum 60 in. long.)

EZLogic® ZONE CONTROLLER – Located in each zone (Diffuse). NEMA 1, 2, IP62. UL Approved.

IOP – Provides 27VDC, 100 watt power for EZLogic® accumulation system - contains slots for 4 input/output boards. Requires 120VAC or 230VAC single phase input.

AIR REQUIREMENTS – Recommended working pressure 60 P.S.I. Free air consumption at 75 P.S.I. - 1.0 cu. ft. per actuation for 24 in. & 27 in. strand centers - 1.5 cu. ft. per actuation for 30 in. - 51 in. strand centers.

FILTER, REGULATOR – Supplied for main air supply line (½ in. NPT port). Includes pressure sensor.

MOTOR – 2 HP – 208/230/460/575V – 3 PH. 60 HZ. gearmotor, located underneath in 5 ft. long module.

CONVEYING SPEED – 30 FPM.

CAPACITY – 12,000 lbs. maximum at 30 FPM (2 HP maximum). NOT TO EXCEED CAPACITY IN CHART.

FLOOR SUPPORTS – Now supplied as optional equipment.

EZLOGIC® ACCUMULATION SYSTEM

Hytrol's EZLogic®, or "Electronic Zero-pressure Logic" Accumulation System, combines the sensing accuracy of photo-electronics with discrete electronic logic control without the use of a PLC or pneumatic logic components. The EZLogic® Accumulation System provides many features including:

Zone Stop - Function is built in. Any zone may be transformed into a workstation by connecting a dry contact switching device to the auxiliary port of the EZLogic® Zone Controller. This feature is always used at the discharge end of the conveyor line, and may be used at any other location where a zone stop is required.

Dynamic Zone Allocation – Automatically adjusts the conveyor's zone length to accommodate the length of the product being conveyed. Improves conveyor efficiency and system flexibility.

Unloading Zone Feature - Zone On Delay – Timer delays the zone immediately upstream from a removed load, preventing it from driving for a set time. This feature is ideal where loads are routinely removed from the conveyor with a lift truck.

Loading Zone Feature – Zone detects load being placed onto the conveyor with a fork truck and stops the zone from driving and automatically prevents any loads in zones upstream from entering loading area.

LOAD CAPACITY CHART (Accumulated or Live)* @ 30 FPM		
HP	TOTAL LOAD (Lbs.)	
	UP TO 50'	UP TO 102'
2	12,000	11,000

*Load capacities in accumulation mode are calculated assuming no more than half of the load will be moving at any time.

MAXIMUM UNIT LOAD - 4000 lbs.



• OPTIONAL EQUIPMENT

FLOOR SUPPORTS – DCDS and DC3S Type floor supports are available with a wide range of adjustment. Specify top of chain elevation. One support required at every bed joint and ends of conveyor. Holes in feet for lagging to floor.

CLOSED TAIL – Overall length will be affected.

MOTORS – Energy efficient, 3 HP maximum.

CONVEYING SPEED – Speeds other than 30 FPM will require gearmotor change (contact factory).

ELECTRICAL MOTOR CONTROLS – Non-reversing magnetic starter – push-button stations.

EZLogic® – See EZLogic® Components Page.