

ROLLER

Gravity Roller Curve Conveyor (2 1/2 in. Dia. Tapered Rollers)

Heavy-duty gravity roller curve conveyor aids in alignment of packages, cartons.

- 12 Widths
- Welded Frame Spacers
- Tapered Rollers—Set High

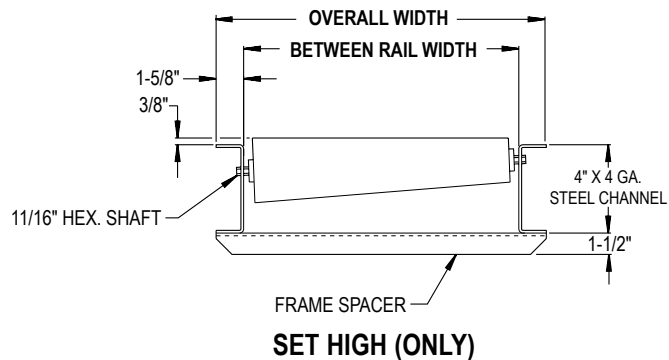
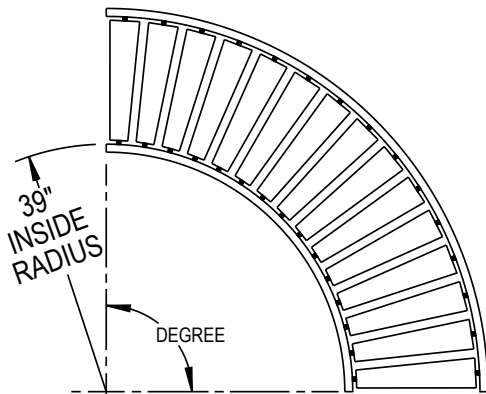

TAPERED ROLLER CURVES								TREAD ROLLER TAPER DIMENSIONS
Overall Width	Between Rail Width	90° Curve	Model No.	Weight (Lbs.)	60° Curve	Model No.	Weight (Lbs.)	
		Number of Rollers			Number of Rollers			
22 1/4"	19"	14	25SRCT-19-90	234	10	25SRCT-19-60	176	2 1/2" to 3 1/2" 11 Ga.
24 1/4"	21"		25SRCT-21-90	242		25SRCT-21-60	182	
26 1/4"	23"		25SRCT-23-90	300		25SRCT-23-60	225	
28 1/4"	25"		25SRCT-25-90	269		25SRCT-25-60	230	2 1/2" to 4" 11 Ga.
30 1/4"	27"		25SRCT-27-90	313		25SRCT-27-60	235	
34 1/4"	31"		25SRCT-31-90	335		25SRCT-31-60	251	
36 1/4"	33"		25SRCT-33-90	356		25SRCT-33-60	267	2 1/2" to 4 1/2" 11 Ga.
40 1/4"	37"		25SRCT-37-90	427		25SRCT-37-60	320	
42 1/4"	39"		25SRCT-39-90	455		25SRCT-39-60	342	
46 1/4"	43"		25SRCT-43-90	504		25SRCT-43-60	378	2 1/2" to 5" 11 Ga.
50 1/4"	47"		25SRCT-47-90	552		25SRCT-47-60	414	
54 1/4"	51"		25SRCT-51-90	600		25SRCT-51-60	450	

All weights in catalog are conveyor weights only. Accessories, crating, etc., are not included.

TAPERED ROLLER CURVES								TREAD ROLLER TAPER DIMENSIONS
Overall Width	Between Rail Width	45° Curve	Model No.	Weight (Lbs.)	30° Curve	Model No.	Weight (Lbs.)	
		Number of Rollers			Number of Rollers			
22 1/4"	19"	7	25SRCT-19-45	122	5	25SRCT-19-30	93	2 1/2" to 3 1/2" 11 Ga.
24 1/4"	21"		25SRCT-21-45	126		25SRCT-21-30	102	
26 1/4"	23"		25SRCT-23-45	155		25SRCT-23-30	110	
28 1/4"	25"		25SRCT-25-45	140		25SRCT-25-30	119	2 1/2" to 4" 11 Ga.
30 1/4"	27"		25SRCT-27-45	162		25SRCT-27-30	128	
34 1/4"	31"		25SRCT-31-45	173		25SRCT-31-30	145	
36 1/4"	33"		25SRCT-33-45	183		25SRCT-33-30	153	2 1/2" to 4 1/2" 11 Ga.
40 1/4"	37"		25SRCT-37-45	219		25SRCT-37-30	171	
42 1/4"	39"		25SRCT-39-45	233		25SRCT-39-30	179	
46 1/4"	43"		25SRCT-43-45	258		25SRCT-43-30	197	2 1/2" to 5" 11 Ga.
50 1/4"	47"		25SRCT-47-45	282		25SRCT-47-30	214	
54 1/4"	51"		25SRCT-51-45	306		25SRCT-51-30	231	

All weights in catalog are conveyor weights only. Accessories, crating, etc., are not included.

