

ROLLER

Gravity Roller Curve Conveyor
 (2 1/2 in. Dia. x 11 Ga. Rollers)
 (2 3/8 in. Dia. x 7 Ga. Rollers)

Heavy-duty gravity roller curve conveyors add versatility to straight gravity roller conveyors. Curves are supplied with 2 1/2 in. dia. rollers mounted in a powder painted steel channel. Curves may be furnished with rollers set high, or with rollers set low to form 3/4 in. high guard rails.

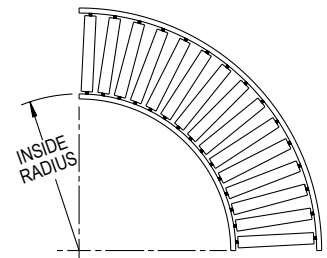

| OAW | BR | Inside Radius | Rollers Per Curve 90° | Model No. 25SRC 2 1/2" Rollers | Weight (Lbs) 90° | Model No. 26SRC 2 3/8" Rollers | Weight (Lbs) 90° | | |
|---------|-----|---------------|-----------------------|--------------------------------|------------------|--------------------------------|------------------|--------------|-----|
| 16 1/4" | 13" | 32 1/2" | 16 Single | 25SRC-13-90S | 170 | 26SRC-13-90S | 196 | | |
| 18 1/4" | 15" | | | 25SRC-15-90S | 185 | 26SRC-15-90S | 216 | | |
| 20 1/4" | 17" | | | 25SRC-17-90S | 200 | 26SRC-17-90S | 235 | | |
| 22 1/4" | 19" | | | 25SRC-19-90S | 212 | 26SRC-19-90S | 252 | | |
| 24 1/4" | 21" | | | 25SRC-21-90S | 230 | 26SRC-21-90S | 274 | | |
| 26 1/4" | 23" | | | 25SRC-23-90S | 245 | 26SRC-23-90S | 294 | | |
| 28 1/4" | 25" | | | 25SRC-25-90S | 260 | 26SRC-25-90S | 313 | | |
| 30 1/4" | 27" | | | 25SRC-27-90S | 276 | 26SRC-27-90S | 333 | | |
| 34 1/4" | 31" | | | 48" | 37 Double | 25SRC-31-90D | 432 | 26SRC-31-90D | 505 |
| 36 1/4" | 33" | | | | | 25SRC-33-90D | 451 | 26SRC-33-90D | 530 |
| 40 1/4" | 37" | 25SRC-37-90D | 589 | | | 26SRC-37-90D | 578 | | |
| 42 1/4" | 39" | 25SRC-39-90D | 508 | | | 26SRC-39-90D | 602 | | |
| 46 1/4" | 43" | 25SRC-43-90D | 546 | | | 26SRC-43-90D | 650 | | |
| 50 1/4" | 47" | 25SRC-47-90D | 583 | | | 26SRC-47-90D | 697 | | |
| 54 1/4" | 51" | 25SRC-51-90D | 622 | | | 26SRC-51-90D | 746 | | |

| OAW | BR | Inside Radius | Rollers Per Curve 45° | Model No. 25SRC 2 1/2" Rollers | Weight (Lbs) 45° | Model No. 26SRC 2 3/8" Rollers | Weight (Lbs) 45° | | |
|---------|-----|---------------|-----------------------|--------------------------------|------------------|--------------------------------|------------------|--------------|-----|
| 16 1/4" | 13" | 32 1/2" | 8 Single | 25SRC-13-45S | 91 | 26SRC-13-45S | 104 | | |
| 18 1/4" | 15" | | | 25SRC-15-45S | 98 | 26SRC-15-45S | 113 | | |
| 20 1/4" | 17" | | | 25SRC-17-45S | 106 | 26SRC-17-45S | 123 | | |
| 22 1/4" | 19" | | | 25SRC-19-45S | 113 | 26SRC-19-45S | 133 | | |
| 24 1/4" | 21" | | | 25SRC-21-45S | 121 | 26SRC-21-45S | 143 | | |
| 26 1/4" | 23" | | | 25SRC-23-45S | 128 | 26SRC-23-45S | 152 | | |
| 28 1/4" | 25" | | | 25SRC-25-45S | 136 | 26SRC-25-45S | 162 | | |
| 30 1/4" | 27" | | | 25SRC-27-45S | 143 | 26SRC-27-45S | 172 | | |
| 34 1/4" | 31" | | | 48" | 19 Double | 25SRC-31-45D | 311 | 26SRC-31-45D | 349 |
| 36 1/4" | 33" | | | | | 25SRC-33-45D | 323 | 26SRC-33-45D | 363 |
| 40 1/4" | 37" | 25SRC-37-45D | 348 | | | 26SRC-37-45D | 393 | | |
| 42 1/4" | 39" | 25SRC-39-45D | 360 | | | 26SRC-39-45D | 408 | | |
| 46 1/4" | 43" | 25SRC-43-45D | 385 | | | 26SRC-39-45D | 438 | | |
| 50 1/4" | 47" | 25SRC-47-45D | 408 | | | 26SRC-47-45D | 467 | | |
| 54 1/4" | 51" | 25SRC-51-45D | 434 | | | 26SRC-51-45D | 498 | | |

| OAW | BR | Inside Radius | Rollers Per Curve 60° | Model No. 25SRC 2 1/2" Rollers | Weight (Lbs) 60° | Model No. 26SRC 2 3/8" Rollers | Weight (Lbs) 60° | | |
|---------|-----|---------------|-----------------------|--------------------------------|------------------|--------------------------------|------------------|--------------|-----|
| 16 1/4" | 13" | 32 1/2" | 10 Single | 25SRC-13-60S | 128 | 26SRC-13-60S | 147 | | |
| 18 1/4" | 15" | | | 25SRC-15-60S | 138 | 26SRC-15-60S | 162 | | |
| 20 1/4" | 17" | | | 25SRC-17-60S | 150 | 26SRC-17-60S | 177 | | |
| 22 1/4" | 19" | | | 25SRC-19-60S | 159 | 26SRC-19-60S | 189 | | |
| 24 1/4" | 21" | | | 25SRC-21-60S | 173 | 26SRC-21-60S | 205 | | |
| 26 1/4" | 23" | | | 25SRC-23-60S | 183 | 26SRC-23-60S | 221 | | |
| 28 1/4" | 25" | | | 25SRC-25-60S | 195 | 26SRC-25-60S | 235 | | |
| 30 1/4" | 27" | | | 25SRC-27-60S | 207 | 26SRC-27-60S | 250 | | |
| 34 1/4" | 31" | | | 48" | 23 Double | 25SRC-31-60D | 324 | 26SRC-31-60D | 378 |
| 36 1/4" | 33" | | | | | 25SRC-33-60D | 339 | 26SRC-33-60D | 398 |
| 40 1/4" | 37" | 25SRC-37-60D | 366 | | | 26SRC-37-60D | 433 | | |
| 42 1/4" | 39" | 25SRC-39-60D | 381 | | | 26SRC-39-60D | 451 | | |
| 46 1/4" | 43" | 25SRC-43-60D | 410 | | | 26SRC-43-60D | 488 | | |
| 50 1/4" | 47" | 25SRC-47-60D | 438 | | | 26SRC-47-60D | 523 | | |
| 54 1/4" | 51" | 25SRC-51-60D | 467 | | | 26SRC-51-60D | 559 | | |

| OAW | BR | Inside Radius | Rollers Per Curve 30° | Model No. 25SRC 2 1/2" Rollers | Weight (Lbs) 30° | Model No. 26SRC 2 3/8" Rollers | Weight (Lbs) 30° | | |
|---------|-----|---------------|-----------------------|--------------------------------|------------------|--------------------------------|------------------|--------------|-----|
| 16 1/4" | 13" | 32 1/2" | 5 Single | 25SRC-13-30S | 57 | 26SRC-13-30S | 65 | | |
| 18 1/4" | 15" | | | 25SRC-15-30S | 61 | 26SRC-15-30S | 72 | | |
| 20 1/4" | 17" | | | 25SRC-17-30S | 66 | 26SRC-17-30S | 78 | | |
| 22 1/4" | 19" | | | 25SRC-19-30S | 70 | 26SRC-19-30S | 84 | | |
| 24 1/4" | 21" | | | 25SRC-21-30S | 75 | 26SRC-21-30S | 91 | | |
| 26 1/4" | 23" | | | 25SRC-23-30S | 81 | 26SRC-23-30S | 97 | | |
| 28 1/4" | 25" | | | 25SRC-25-30S | 86 | 26SRC-25-30S | 103 | | |
| 30 1/4" | 27" | | | 25SRC-27-30S | 91 | 26SRC-27-30S | 110 | | |
| 34 1/4" | 31" | | | 48" | 13 Double | 25SRC-31-30D | 143 | 26SRC-31-30D | 167 |
| 36 1/4" | 33" | | | | | 25SRC-33-30D | 148 | 26SRC-33-30D | 175 |
| 40 1/4" | 37" | 25SRC-37-30D | 161 | | | 26SRC-37-30D | 191 | | |
| 42 1/4" | 39" | 25SRC-39-30D | 167 | | | 26SRC-39-30D | 198 | | |
| 46 1/4" | 43" | 25SRC-43-30D | 181 | | | 26SRC-43-30D | 215 | | |
| 50 1/4" | 47" | 25SRC-47-30D | 192 | | | 26SRC-47-30D | 230 | | |
| 54 1/4" | 51" | 25SRC-51-30D | 205 | | | 26SRC-51-30D | 246 | | |

• STANDARD SPECIFICATIONS

WIDTHS—Between Rail Width 13 in., 15 in., 17 in., 19 in., 21 in., 23 in., 25 in., 27 in., 31 in., 33 in., 37 in., and 39 in., 43 in., 47 in., & 51 in.

FRAME—4 in. deep x 1 1/2 in. flange x 4 ga. powder painted formed steel channel with bolt-in cross members set high, welded cross members set low.

BUTT COUPLINGS—For bolting sections together.

CURVES—30°, 45°, 60° and 90° with 32 1/2 in. inside radius up to 27 in., 48 in. inside radius on 31 in. to 51 in. between rail widths.

ROLLERS—25-SRC 2 1/2 in. dia. x 11 ga. steel tubing. Bearings are labyrinth sealed and grease packed.

AXLES—1 1/2 in. hex shaft, spring loaded.

CAPACITY—Same per foot capacity as straight sections. See charts previous page.

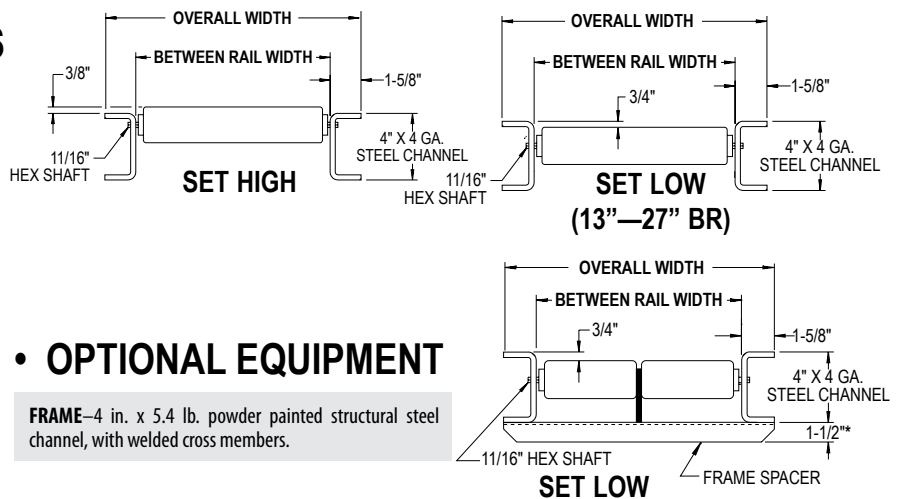

• OPTIONAL EQUIPMENT

FRAME—4 in. x 5.4 lb. powder painted structural steel channel, with welded cross members.

*Frame spacer 1 1/2" below channel on 31" to 51" BR only.

