

FXG

Parcel Belt Conveyor

Designed for the parcel handling industry with bolted construction.

- 4 Belt Widths
- Center Drive with 8", 12" or 16" Dia. Drive Pulley
- Adjustable FXG-Type Floor Supports Available
- Less Belt, supplied by customer



Conveyor shown with floor supports and cable rail.

SIZE TO ORDER Overall Length "A"		Belt Width Pan Width	Supplied by customer			
			35.5"	41.5"	47.5"	59.5"
		Overall Frame Width	37.02"	43.02"	49.02"	61.52"
19'-3" (includes 8" or 12" drive)	20'-6" (Includes 16" drive)	WEIGHTS (Lbs.)	1686	1865	2042	2219
per 2 feet	per 2 feet		82	90	100	108
ADD TO ABOVE WEIGHTS FOR THE FOLLOWING ACCESSORIES:						
• Underside take-up (manual)			294	331	368	405
• Noseover with 2 pulley hitch			274	308	342	376
• Per 10' Int. section with support			414	457	500	543

Above weights include 10" high guards, FXG-6 supports, and 8" or 12" center drive.
Accessories, crating, etc., are not included.
Bed lengths available: 2', 4', 6', 8' and 10'.

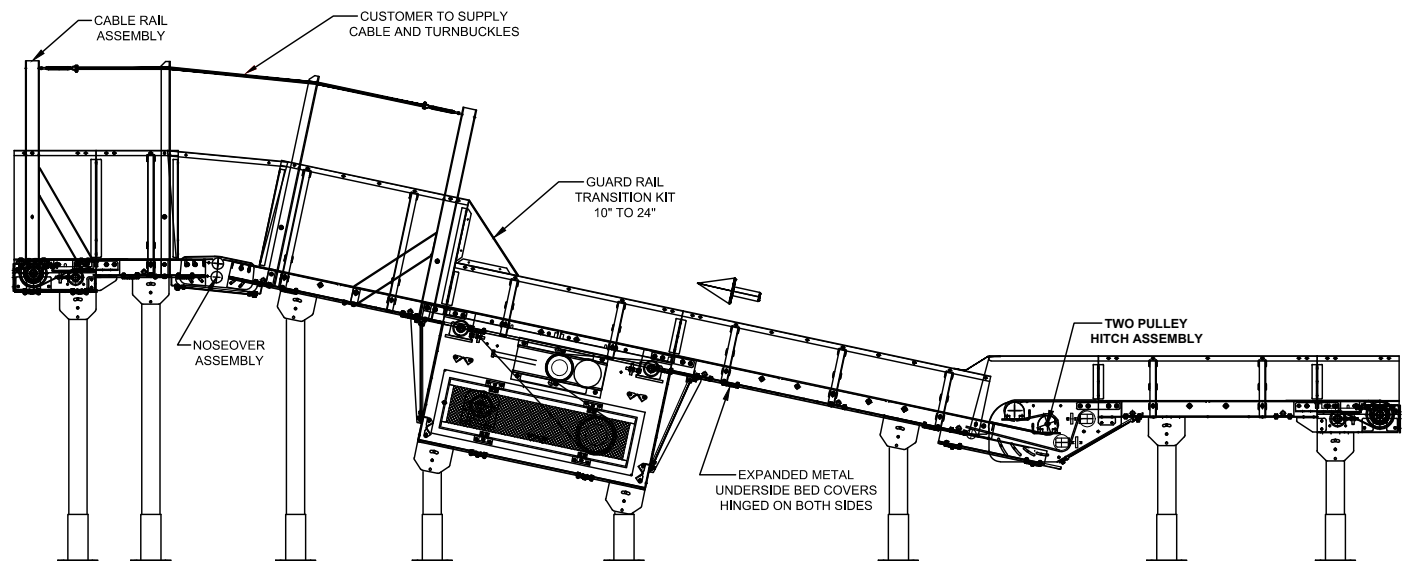
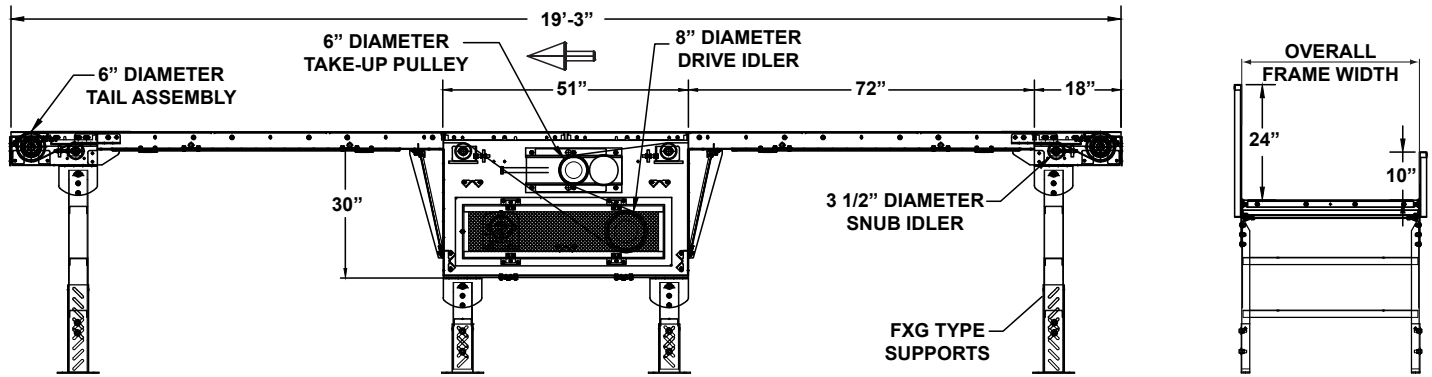

• STANDARD SPECIFICATIONS

BELT—Supplied by Customer.

BED—12 ga. formed steel slider bed bolted between two 3 5/8 in. deep x 10 ga. formed steel side channels. Standard 2, 4, 6, 8 and 10 ft. long sections.

CENTER DRIVE—Minimum elevation—30 in. with 8" and 12" drive, 16" drive
Note: Heavy Duty 12" - 35" Minimum elevation

DRIVE PULLEY—8", 12", and 16" dia. with 2 7/16 in. dia. removable shaft, fully lagged.
Note: Heavy Duty 12" with 2 15/16 in. dia. removeable shaft bearings, fully lagged.

TAIL PULLEY—6 in. dia. with 1 15/16 in. dia. shaft at bearings, machine crowned.

SNUB IDLER—Adjustable 3 1/2 in. dia. with HD pre-lubricated ball bearings.

BEARINGS—Sealed, pre-lubricated, self-aligning, cast-iron ball bearings on drive and tail pulleys.

SPEED REDUCTION—Sealed worm gear C-Face speed reducer. No. 80, or 100 roller chain and timing belt to drive pulley depending on speed and length.

MOTOR—1 HP—208/230/460/575V—3 Ph.—60 Hz. Premium Energy Efficient C-Face.

BELT SPEED—Constant 60 FPM.

CAPACITY—Maximum load per linear foot of conveyor 50 lbs.

• OPTIONAL EQUIPMENT

FLOOR SUPPORTS—FXG Type floor supports are available with a wide range of adjustment. Specify top of belt elevation. One support required at every bed joint and ends of conveyor. Holes in feet for lagging to floor. Knee bracing not included.

BELT—Supplied by Customer. Contact Factory for Application Information.

BELT SPEED—Other constant or variable.

UNDERSIDE BED COVERS—Hinged expanded metal.

NOSEOVER—Single nose for transition of product from incline to horizontal.

TWO-PULLEY HITCH—For transition of product from horizontal to incline.

CABLE RAIL ASSEMBLY—For mounting Cable.

T-RAIL—For mounting extendables.

RETURN IDLER—2 1/2 in. diameter with HD Bearings.

POLY-TIER SUPPORTS—Contact Factory.

CEILING HANGERS—Contact Factory

MOTORS—2, 3, 5 and 7 1/2 HP available.

ELECTRICAL CONTROLS—One direction manual start switch, non-reversing starters, push button stations. AC variable frequency drive.

SIDE GUARDS—Available 10 in. to 24 in. high vertical.

MANUAL UNDERSIDE TAKE-UP—Provides 16 in. of belt take-up

PNEUMATIC & FIXED DIVERTERS—Contact Factory.

BEDS—10 ga. formed steel slider pans and 4 ga. steel slider pans, slider pans with relief rollers.