

2200 & 2300 SERIES: iDRIVE

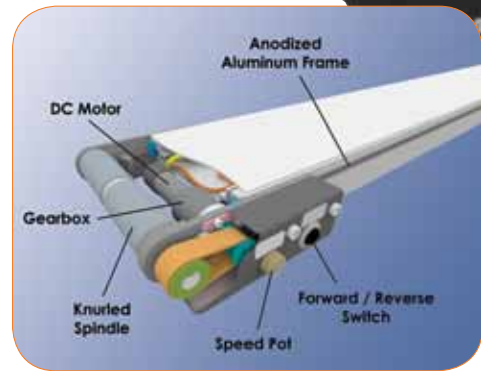

Specifications:

- Sealed ball bearings
- Belt Widths: 2" (51 mm) to 18" (457 mm)
- Conveyor Lengths: 18" (457 mm) to 8' (2,438 mm)
- Belt Speeds: Variable Speed, (4) Speed Options
 - 1.7 to 17 ft/min (0.5 to 5 m/min)
 - 3 to 24 ft/min (0.9 to 7 m/min)
 - 5 to 50 ft/min (1.5 to 15 m/min)
 - 7 to 70 ft/min (2 to 21 m/min)
- Conveyor Load Capacity (non-accumulated, distributed load):
 - 1.7 to 17 ft/min – Up to 25 lbs (11.3 kg)
 - 3 to 24 ft/min – Up to 25 lbs (11.3 kg)
 - 5 to 50 ft/min – Up to 25 lbs (11.3 kg)
 - 7 to 70 ft/min – Up to 12 lbs (5.4 kg)
- Indexing Capable – Up to 30 indexes per minute



Features & Benefits:

- Internally mounted gearmotor and control for space savings and tight work spaces
- Reduced integration time required to mount and wire the total conveyor package
- Ideal combination of conveyor and gearmotor sizing for small parts handling
- Variable Speed and reversible for maximum application flexibility
- Control switches conveniently located in high impact protective case
- 1.25" diameter drive roller for smooth product transfer
- V-guided belts for maintenance-free belt tracking (4" and wider only)
- Maintenance-free brushless DC motor



OPTIONAL: Customer Wired Controls

For ease of automation integration.



OPTIONAL: 8 mm Nose Bar Transfer

Available at non-driven end.
Speeds up to 75 ft/min (22 m/min).

Two Side Rail Options:

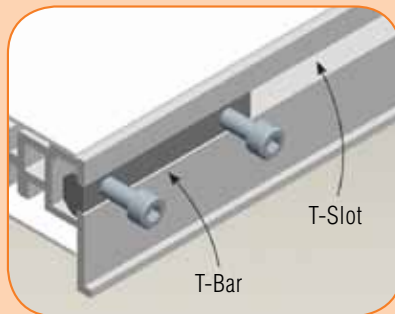

2200 T-Slot Technology:
Drop in T-bar for ease and flexibility
in mounting accessories

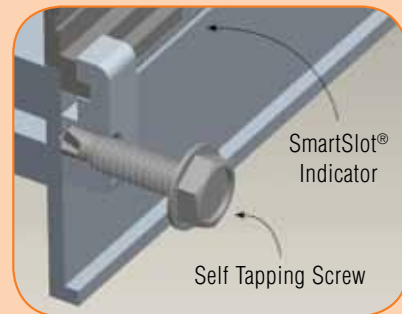

2300 SmartSlot® Technology:
Functions like a T-Slot without
collecting debris

For support stands and accessories, see pages 62-73.

For ordering information, see page 74

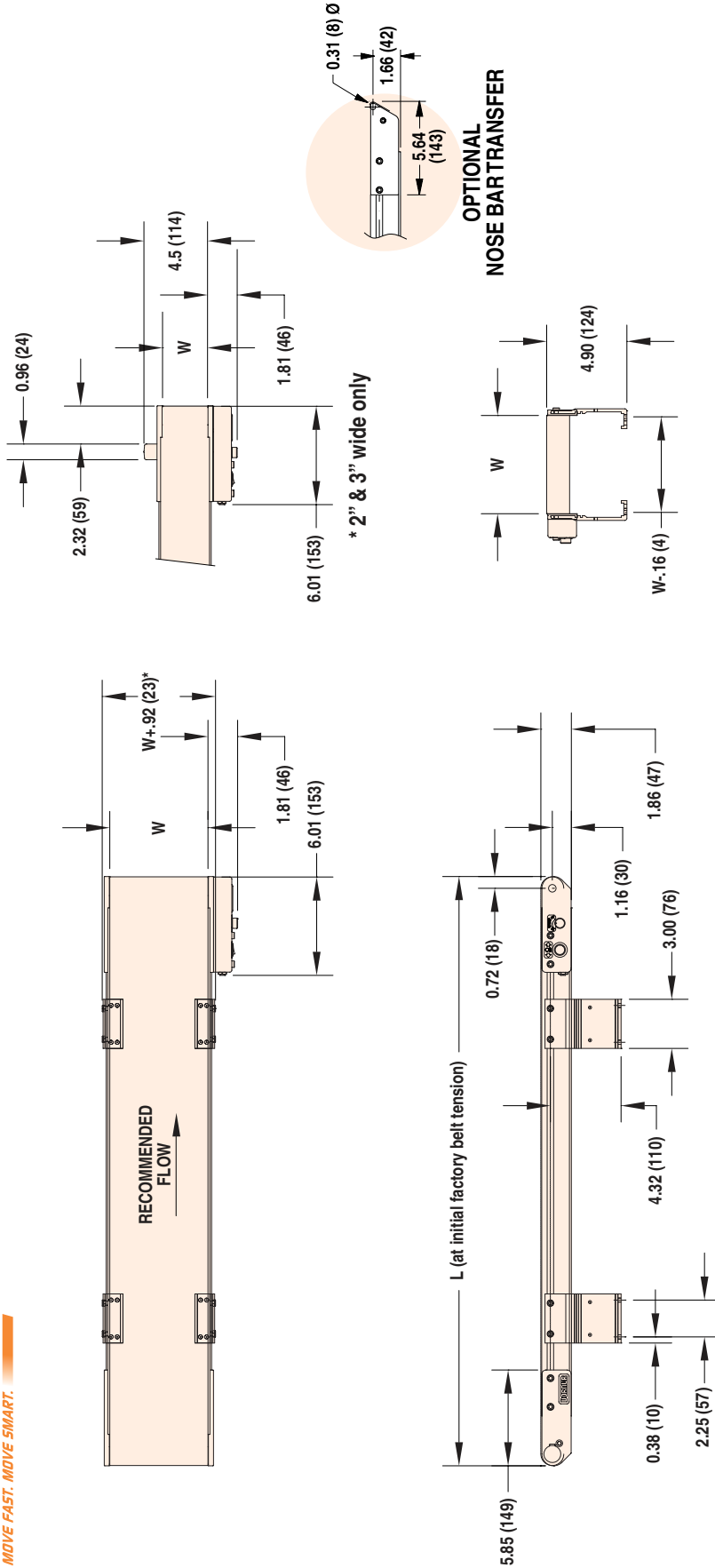

W = Conveyor Belt Width **Dim** = in (mm)

STANDARD SIZES										
Conveyor Width Reference	02	03	04	05	06	08	10	12	18	
Conveyor Belt Width (W)	1.75" (44mm)	2.75" (70mm)	3.75" (95mm)	5" (127mm)	6" (152mm)	8" (203mm)	10" (254mm)	12" (305mm)	18" (457mm)	
Conveyor Length Reference	0150		0001 increments up to...						0800	
Conveyor Length (L)	1.5' (457mm)		0.12" (3mm) increments up to...						8' (2,438mm)	

NOTE: Duty cycle not continuous rated.

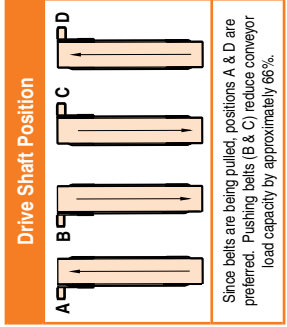

For more information, go to www.dorner.com. Call 800.397.8664 or 262.367.7600.
Due to the wide variety of drive set ups and applications, point of installation guarding is the responsibility of the end user.