

# ABEZ

## Live Roller Conveyor (Zero Pressure Accumulating Type)

The Model ABEZ is a horizontal belt driven live roller conveyor, designed for applications that require accumulation of products without a build-up of line pressure. Product may be released in singulation or slug fashion.

- EZLogic® Accumulation System
- Singulation, Slug or Cascaded Slug Operation
- Dynamic Zone Allocation
- 4 Brake Rollers in Each Zone
- Adjustable MS-Type Floor Supports Available



Conveyor shown with optional floor supports



U.S. Patent Numbers  
5,862,907 • 7,243,781 • 7,591,366  
Other Patents Pending.



Between Rail Width	15"	17"	19"	21"	23"	25"	27"	31"	33"	37"	39"
Overall Frame Width	18"	20"	22"	24"	26"	28"	30"	34"	36"	40"	42"
Base Weight	670	693	716	739	762	785	808	854	877	923	946
Weight Per Foot	31	33	35	37	39	41	43	47	49	53	55

All weights in catalog are conveyor weights only. Accessories, crating, etc., are not included.

**Note:** Bed sections available in the following multiples:

- |  |                    |
|--|--------------------|
| 12" Zones—1, 2, 3, 4, 5, 6, 7, 8, 9' & 10'       | 48" Zones—4' & 8'  |
| 18" Zones—1 1/2, 3, 4 1/2, 6, 7 1/2 & 9'         | 60" Zones—5' & 10' |
| 24" Zones—2, 4, 6, 8' & 10'                      | 72" Zones—6'       |
| 30" Zones—2 1/2, 5, 7 1/2' & 10'                 | 84" Zones—7'       |
| 36" Zones—3, 6' & 9'                             | 96" Zones—96'      |
| Overall length must be divisible by zone length. | 120" Zones—120'    |

Total Weight = 10' Base Weight + per foot weight x extra length

**NOTE:** 18" & 24" Overall Frame Width (24" & 30" Zones)  
-1 Week Stockyard

## HOW IT WORKS

The conveyor is divided into accumulation zones. Each zone extracts power from a flat drive belt that runs the entire length of the conveyor. The drive belt is pneumatically lowered away from the tread rollers, causing product in that zone to stop. Hytrol's EZLogic® Zone Controllers sense product presence and control the accumulation and release of product from the zones.

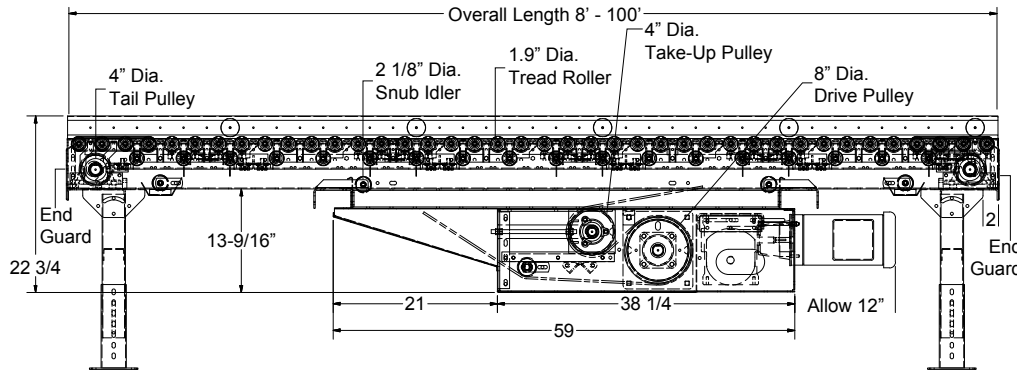

**SET HIGH SHOWN WITH STANDARD DRIVE**  
(Located in First Bed Section 8' or Longer, From Infeed End)

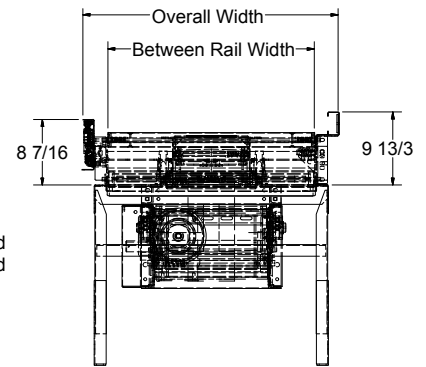

**SECTION "X-X"**

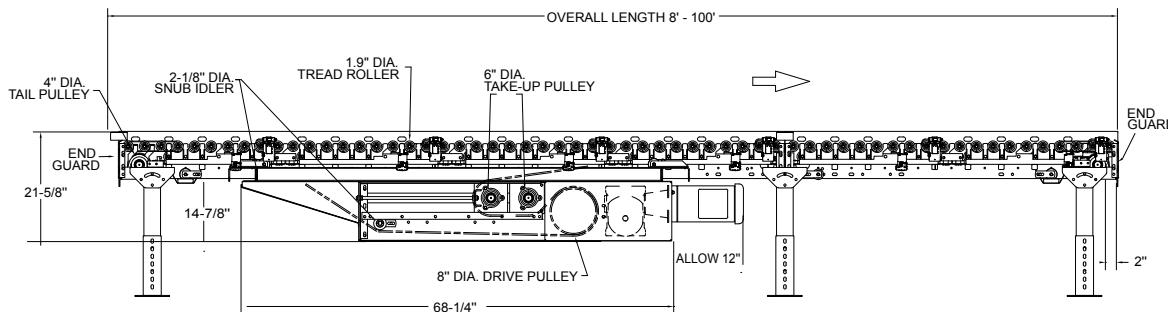

**SET LOW SHOWN WITH HIGH PERFORMANCE DRIVE**  
(Located in First Bed Section 9' or Longer, From Infeed End)

**SECTION "X-X"**



## • STANDARD SPECIFICATIONS

**BELT**—6 in. Black Ultimate 140 SD.

**BED**—Roller bed with 1.9 in. dia. roller x 16 ga. galvanized tube spaced every 3 in. Mounted in 6 1/2 in. x 12 ga. powder painted formed steel channel frame bolted together with butt coupling.

**CROSS BRACING**—Rods with turnbuckle are fastened to underside of bed to provide proper alignment of bed rollers and insure correct product tracking. Supplied on every other section 30 ft. bed lengths and over.

**CENTER DRIVE**—Can be placed in any section of conveyor 7'-6" or longer. Center drive is 18 in. OAW on all widths.

**DRIVE PULLEY**—8 in. dia. with 1 7/8 in. dia. shaft at bearings.

**TAIL PULLEY**—4 in. dia. with 1 7/8 in. dia. shaft at bearings, machine crowned.

**TAKE-UP PULLEY**—6 in. dia. with 1 3/8 in. dia. shaft at bearings, machine crowned.

**SNUB IDLER**—Adjustable 2 1/2 in. dia. pre-lubricated ball bearings.

**RETURN IDLER**—Adjustable 1.9 in. dia. pre-lubricated ball bearings.

**TAKE-UP**—Take-ups in center drive. Provides 16 in. of belt take-up.

**BEARINGS**—Sealed, pre-lubricated, self-aligning, ball bearings on drive and tail pulleys. Pre-lubricated ball bearings in tread and pressure rollers.

**SET LOW CHANNEL**— Added additional flanges to make the installation and removal of the optional cover simple.

**ACCUMULATION ZONES**—12, 18, 24, 30 and 36 in. long air controlled. Includes 4 brake rollers to stop package. Section lengths change with zone lengths. (See **Note** opposite page). **Note:** 51 or more zones will require an additional IOP, isolation cable and power supply T cable.

**EZLogic<sup>®</sup> ZONE CONTROLLER** — Located in each zone. (Retro-reflective). NEMA 1, 2, IP 62. UL Approved.

**IOP**—Provides 27VDC, 100 watt power for EZLogic<sup>®</sup> accumulation system - contains slots for 4 input/output boards. Operates up to 50 zones (25 each side of IOP). Requires 120VAC or 230VAC single phase input.

**AIR REQUIREMENTS**—Recommended working pressure 35 P.S.I. Free air consumption at 35 P.S.I.—.003 cu. ft. per sensor actuation.

**FILTER, REGULATOR**—One filter/regulator is supplied for the main air supply line. (3/8 inch NPT port). Main air from compressor should be supplied to each filter/regulator.

**SPEED REDUCTION**—Sealed worm gear C-Face speed reducer. No. 50 roller chain to drive shaft.

**MOTOR**—1/2 HP—208/230/460/575V—3 Ph. 60 Hz. Totally Enclosed C-Face.

**CONVEYING SPEED**—Constant 65 FPM.

**CAPACITY**—Maximum load per linear foot of conveyor 150 lbs. Total load NOT TO EXCEED capacity in charts.

**FLOOR SUPPORTS**—Now supplied as optional equipment.

### EZLOGIC<sup>®</sup> ACCUMULATION SYSTEM

Hytrol's EZLogic<sup>®</sup>, or "Electronic Zero-pressure Logic" Accumulation System, combines the sensing accuracy of photo-electronics with discrete electronic logic control without the use of a PLC or pneumatic logic components. The EZLogic<sup>®</sup> Accumulation System provides many features including:

#### Zero-Pressure Accumulation of Product

Zone Stop function is built in. Any zone may be transformed into a workstation by connecting a dry contact switching device to the auxiliary port of the EZLogic<sup>®</sup> Zone Controller. This feature is always used at the discharge end of the conveyor line, and may be used at any other location where a zone stop is required.

#### Selectable Modes of Operation

**Singulation Mode** — Product separates while traveling down the conveyor and when it is released from the conveyor - creating a zone-length gap between products.

**Enhanced Slug Mode w/ Jam Protection** — Product does not separate when traveling down the conveyor or when it is released from the conveyor. This allows higher product throughput at any given conveyor speed. Product will not separate on the conveyor even when accumulation has been activated at the discharge end.

**Cascaded Slug Release** — Rather than releasing all zones simultaneously, this function introduces a momentary delay in the release of each zone, from discharge upstream.

**Dynamic Zone Allocation** — Automatically adjusts the conveyor's zone length to accommodate the length of the product being conveyed. Improves conveyor efficiency and system flexibility.

HP	OVERALL FRAME WIDTH 18" TO 22"		OVERALL FRAME WIDTH 24" TO 30"		OVERALL FRAME WIDTH 34" TO 42"	
	TOTAL LOAD (LBS.)		TOTAL LOAD (LBS.)		TOTAL LOAD (LBS.)	
	UP TO 50'	UP TO 100'	UP TO 50'	UP TO 100'	UP TO 50'	UP TO 100'
1/2	2200	400	1200	—	—	—
1	6600	4800	5600	3200	4400	—
2	*7500	12000	*7500	10400	*7500	6600

\*Limited to 150 lbs. per foot

HP	OVERALL FRAME WIDTH 18" TO 22"		OVERALL FRAME WIDTH 24" TO 30"		OVERALL FRAME WIDTH 34" TO 42"	
	TOTAL LOAD (LBS.)		TOTAL LOAD (LBS.)		TOTAL LOAD (LBS.)	
	UP TO 50'	UP TO 100'	UP TO 50'	UP TO 100'	UP TO 50'	UP TO 100'
1/2	1100	200	600	—	—	—
1	3300	2400	2800	1600	2200	—
2	7000	6000	6400	5200	5800	3300

## • OPTIONAL EQUIPMENT

**FLOOR SUPPORTS**—MS Type floor supports are available with a wide range of adjustment. Specify top of belt or roller elevation. One support required at every bed joint and ends of conveyor. Holes in feet for lagging to floor. Knee braces recommended above MS-6 support.

**CONVEYING SPEED**—Other constant and variable speeds. FPM. V-belt drive supplied under 17 FPM. **Note:** Capacity and accumulation feature affected with speed change.

**CENTER DRIVE WITH EXTENDED TAKE UP**— Provides 36 in. of additional belt take up.

**HIGH PERFORMANCE UNDERSIDE CENTER DRIVE**—Required on units over 100 ft long, maximum length 200'-0" (used with 2 HP, 3 HP or 5 HP motor and reducers).

**SIDE MOUNTED LOW ELEVATION CENTER DRIVE**—Motor reducer unit mounted to side of conveyor. Minimum low elevation 16 in.

**PRESSURE SWITCH**—Installed in air line after regulator unit. Kills conveyor drive when air pressure drops below minimum working requirements. Requires restart controller (not supplied).

**V-BELT DRIVE**—V-Belt supplied between motor and reducer. Allow 65 in.

**O-RING DRIVE CHAIN**—With sealed in lubricant (Recommended for applications that do not permit regular lubrication).

**GUARD RAILS**—Adjustable Universal Channel Guard Rail. See Accessory section. **Note:** If product comes into contact with Guard Rails, product flow will be affected. Fixed channel overlapping-one direction.

**PACKAGE STOPS**—Angle and raised roller end stops.

**POLY-TIER SUPPORTS**—36 in. to 120 in. support heights in 6 in. increments. Knee braces required.

**CEILING HANGERS**—5/8 in. dia. x 8 ft. long unplated steel rods fully threaded. Other lengths and galvanized rods available.

**MOTORS**—Energy efficient, single phase, other characteristics. 2 HP maximum.

**ELECTRICAL MOTOR CONTROLS**—Non-reversing magnetic starters and push-button stations. AC variable frequency drive.

**EZLogic<sup>®</sup>** — See EZLogic<sup>®</sup> Components Page.